

# Cryogenic Valves



**MICROFINISH VALVES**

*Quality you can trust.*

## Cryogenic Valves

Cryogenic service in industrial valve applications is defined as at or below  $-50^{\circ}\text{C}$  ( $-58^{\circ}\text{F}$ ). Liquefied Natural Gas (LNG), Liquid Oxygen (LOX), Liquid Nitrogen (LN2) are some common cryogenics handled by cryogenic service valves.

The challenge involved in the design of cryogenic valves is immense. The valve must function properly at pressures as high as ASME Class 2500 and at temperatures as low as  $-269^{\circ}\text{C}$  ( $-452^{\circ}\text{F}$ ). The design starts with selecting the materials suitable for extremely low temperatures; then determining the dimensions of pressure containing parts and trim elements. Precise tolerances are set for those parts to be subjected to thermal shock and shrinkage. Furthermore some cryogenics such as LOX and LNG are flammable; so the valve must be designed to be fire safe as specified in API 607 and ISO 10497 standards.

Microfinish has worked with EPC and end user companies for more than 30 years and earned a reputation for quality and reliability in its comprehensive range of valve products. It has established an extensive installed base of cryogenic valves and automation packages for ethylene plants, Air Separation Units (ASU), and the entire LNG value chain.

### Standards of compliance

Factory certification:

- ISO 9001-2015 Quality management system
- Valve design and tests:
  - ANSI B16.34; ISO 17292; API 608; API 6D / ISO 14313
  - BS 6364 Specification for valves for cryogenic service
  - ISO 28921-1 Industrial valves: isolating valves for low temperature applications (optional)
  - EN 12266-1; API 598 Testing of metallic valves
  - API 6FA; API 607; ISO 10497 Testing of valves to fire type-testing requirements
  - ISO 15848-1 measurement, test and qualification procedures for fugitive emissions
  - API 641 Type Testing of Quarter-turn Valves for Fugitive Emissions

## Serving the entire LNG value chain

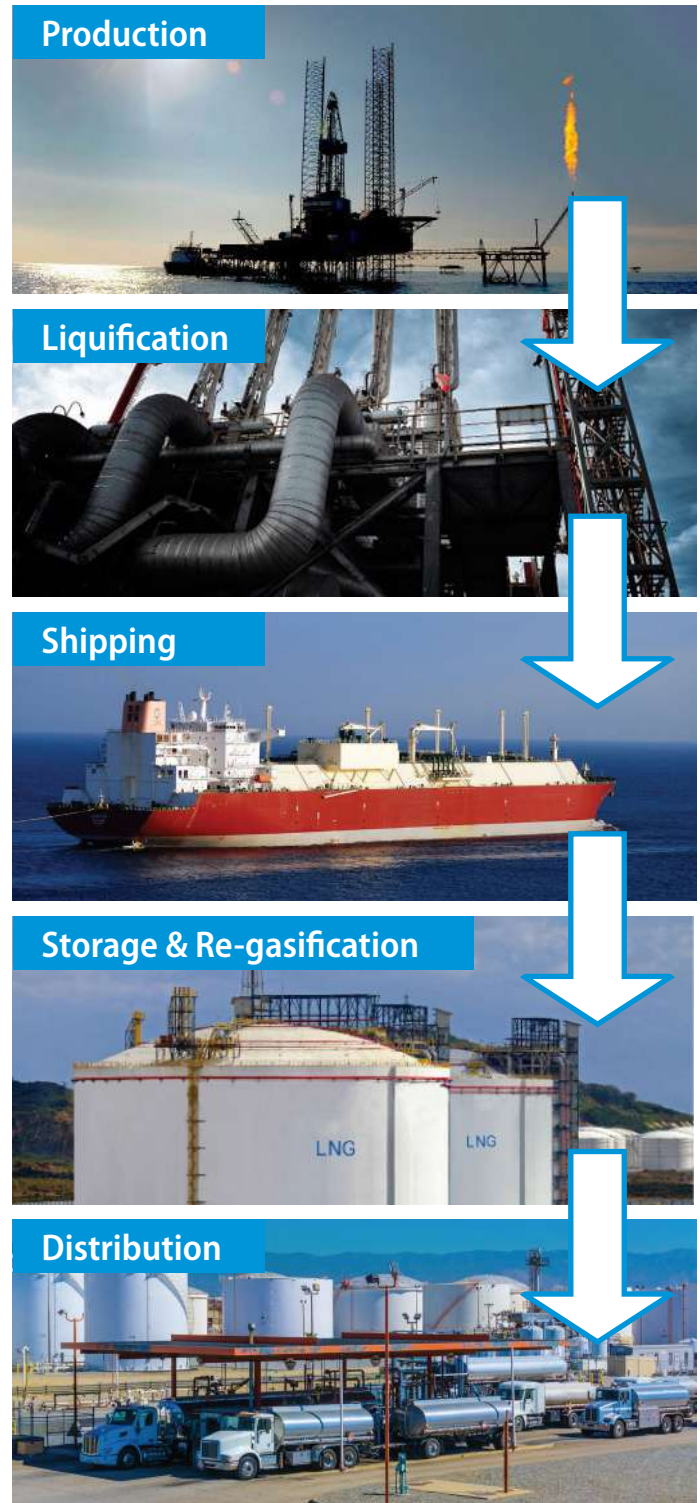

# Our Technology

## Design

Microfinish introduced to the market a distinctive design of trunnion mounted ball valve for cryogenic service. The design is built as per BS6364 and API 6D, DIB-2 configuration. With the valve in its closed position, both upstream and downstream seats work in tandem to block in-line leak. Cavity pressure build-up, due to thermal expansion, is released safely through the upstream SPE seat design. Microfinish's proven valve design can increase significantly the MTTF and MTBF of trunnion mounted valves in extreme cryogenic temperature conditions, and hence maximizes plant productivity and site safety.

## Cleaning

Microfinish cleaning procedures are in full compliance with the following international standards and corporate specifications: CGA G-4.1, ASTM A380/A380M; EIGA 33.06; Linde standard LS 141-47 part 1 and 2; Linde standard LS 031-6X7; Praxair standard GS-38 and GS-40; and Reliance standard spec No.100080-1-SS-PP-004-Part IV App. B and E. Microfinish's verified and repeatable cleaning process including 100% cleaning inspection eliminates hydrocarbon, oil, grease, metal chips and other ignition hazards that can be introduced by a deburring process or shop dirt.

## Assembly

Valves are assembled in an oil free zone. This designated area is equipped with dedicated clean tools. Valve assembly is done by trained personnel who are qualified for this particular task. The employees wear clean working clothes and latex gloves throughout the complete process of assembly, testing, and packing the final product in a clean plastic bag ready for shipping.

## Testing

The complete assembled cryogenic valve is meticulously tested to meet EN 12266-1, API 598, ISO 5208, and API 6D standards including:

- Hydrostatic shell test at 1.5 times the valve pressure rating, before the cleaning process commences.
- In-line seat test using 99.999% clean compressed nitrogen at 1.1 times the valve pressure rating.
- Functional test using the method in EN 1779 with vacuum technique: A.3 helium leakage  $\leq 1E-6$  Pa mm<sup>3</sup>/sec
- All pressure containing cast parts rated class 600 and above, and all welded parts are tested radiographically as per ASME B16.34 standard for severe cyclic service.
- Cryogenic test service in compliance with BS 6364 standard is available in-house upon request.
- Additional in-house optional tests are listed in the 'build your cryogenic valve code' section of this Catalog.



## Unique features

### Trunnion mounted cryogenic ball valve

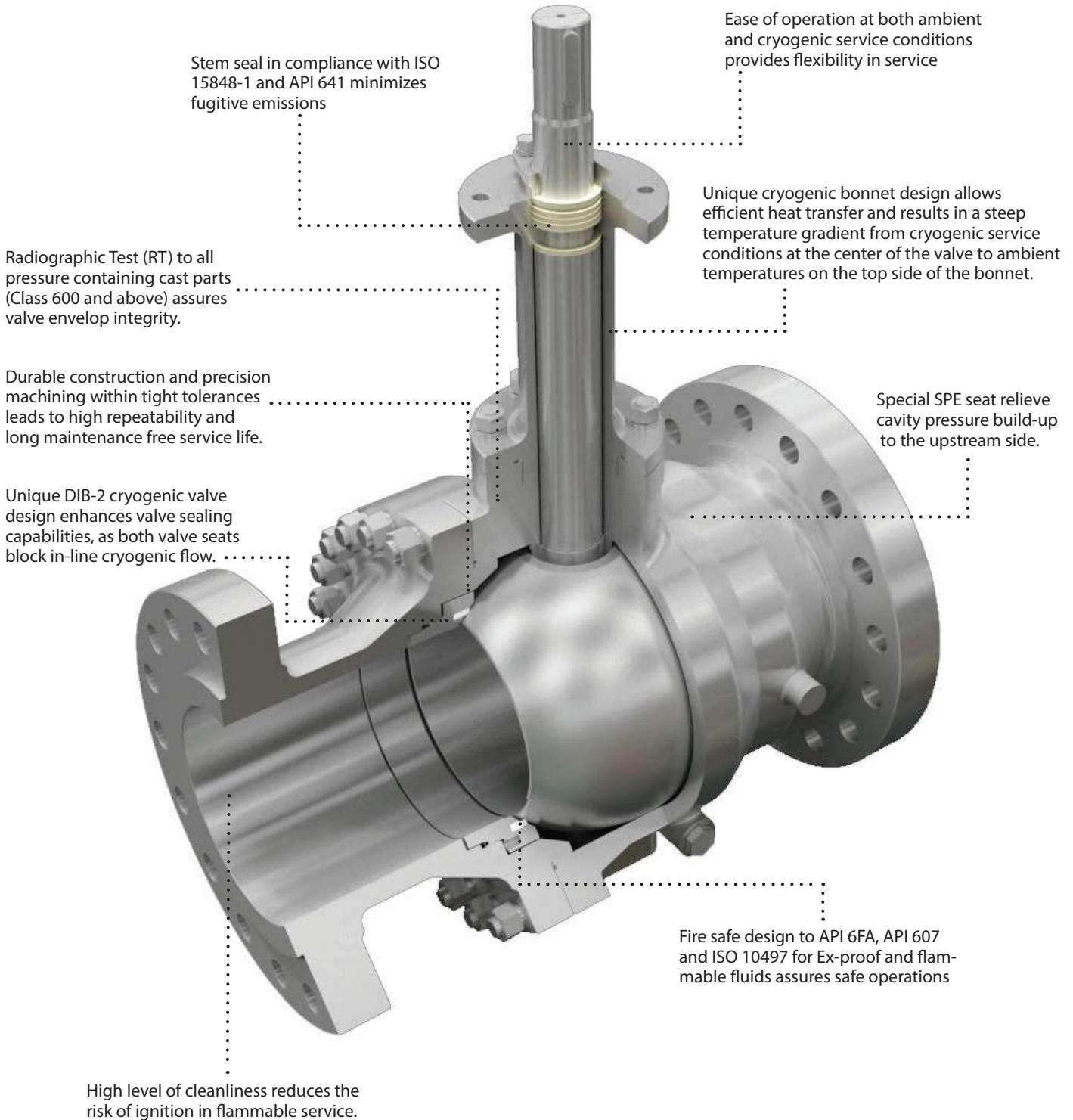

# Unique features

## Cryogenic floating ball valve

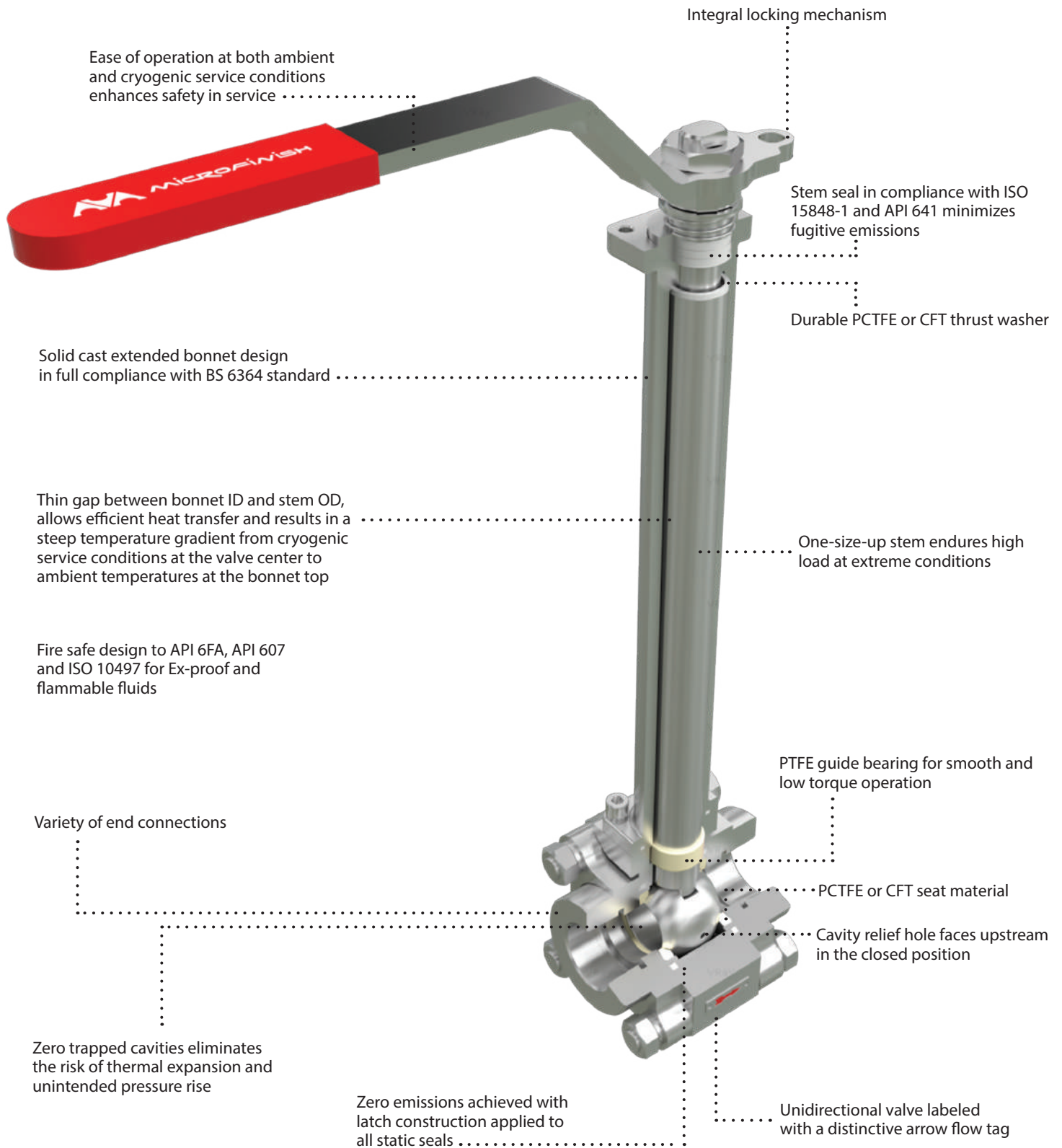

## Our range

### Trunnion mounted ball valves for cryogenic service

Series	Pressure class	Full port size range	Construction	End connections
CT84	150	2"-36"	API 6D DIB-2; full, reduced, and double reduced bore; two and three piece;	Butt-Weld, Socket-Weld, flanged
CT85	300	2"-36"		
CT87	600	2"-36"		
CT89	900	2"-24"		
CT90	1500	2"-24"		
CT91	2500	2"-12"		

### Floating ball valves for cryogenic service

Series	Pressure class	Full port size range	Construction	End connections
C84	150	1/2"-10"	Full bore and reduced bore; one and two piece design	Flanged
C85	300	1/2"-10"		
C87	600	2"-6"	Full bore and reduced bore; three piece design	Threaded, Butt-Weld, Socket-Weld, flanged
		1/2"-2"RP		
		1/2"-4"	Full bore and reduced bore; one and two piece design	Flanged
C89	900	1/2"-2"	Full bore and reduced bore; three piece design	Threaded, Butt-Weld, Socket-Weld, flanged
C90/C91	2500/ 1500	1/2"-2"		

### Pressure-Temperature (P-T) chart for PCTFE (KEL-F) and Carbon Filled TFE (CFT) seat material

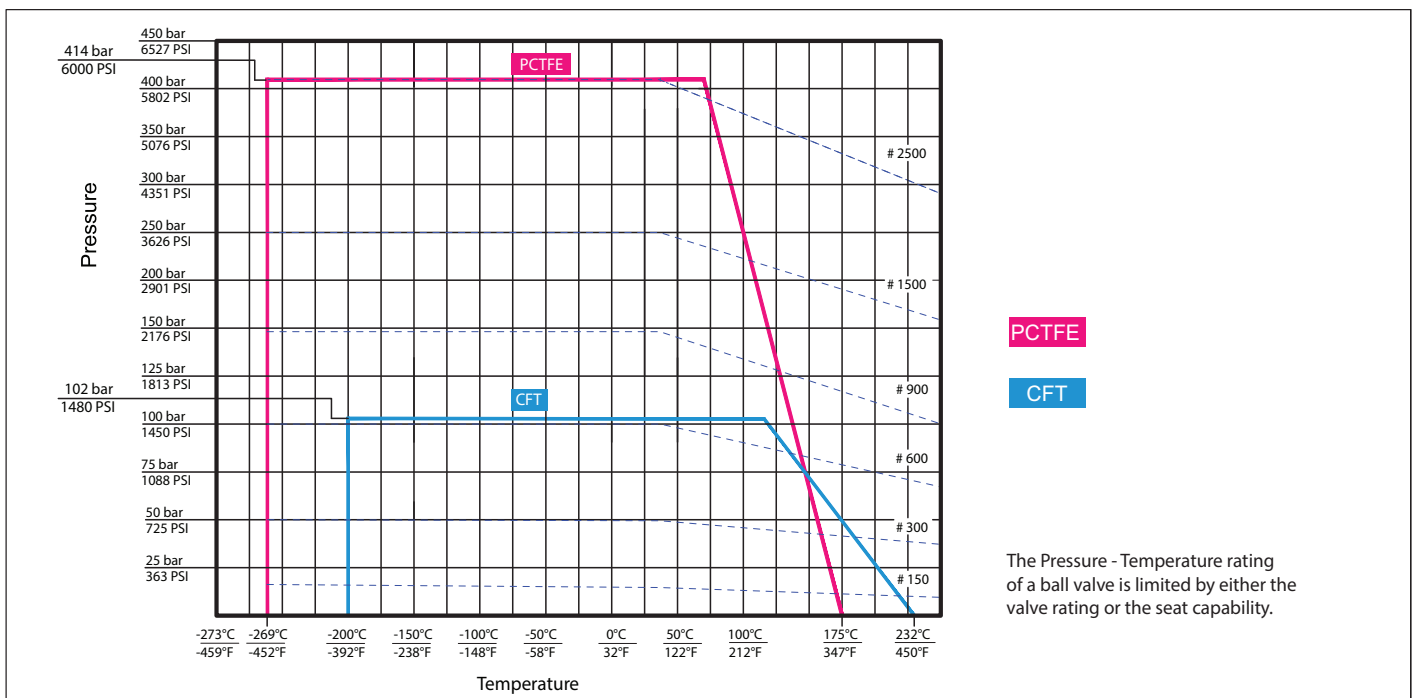

## DIB-2 cryogenic trunnion mounted valve

### Single Piston Effect (SPE) seats

Most trunnion mounted ball valves in industry are based on double-block-and-bleed (DBB) designs. Two identical seats are assembled symmetrically on the upstream and downstream sides of the ball to create a bi-directional valve. With the ball in the closed position both seats block in-line flow into the valve cavity, hence creating a perfectly insulated barrier at atmospheric pressure between the upstream and downstream lines.

In the event of build-up of pressure in the valve cavity the seats are designed to yield and relieve excess pressure in-line. This safety feature is critical, especially in services which are sensitive to thermal expansion such as all cryogenic applications. For example: LNG at  $-162^{\circ}\text{C}$  occupies about  $1/600^{\text{th}}$  the volume of natural gas in the gaseous state. Another way to look at it is: LNG in a closed vessel at 1 bar pressure will vaporise to **600 bar** pressure in the gaseous state!

The drawback of the SPE design is that it relies on only one upstream seat to block in-line flow. In the event of seat damage a leak into the cavity will build sufficient pressure to push the downstream seat backwards. This will disconnect the ball seat sealing surface resulting in free flow in-line.

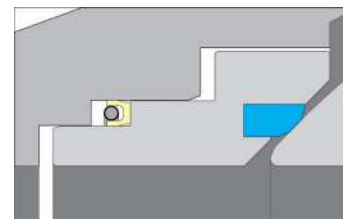

SPE Seat

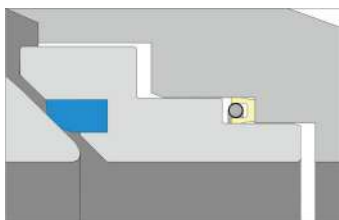

DPE Seat

### Double Piston Effect (DPE) seat

The DPE seat design is used rarely in industry because it has no integral mechanism for relieving build-up of cavity pressure. A valve with DPE seats will normally include an external pressure relief mechanism for the valve cavity. In the event of excess pressure the cavity contents will be released to the environment creating a concern for safety. On the positive side, valves with DPE seats dramatically extend the life time in service. This is because both upstream and downstream seats are working to block in-line leaks. Even when the upstream seat is damaged, the downstream seat will act as a secondary backup to block the leak.

### Microfinish cryogenic DIB-2 valve design

Microfinish has created a superior design as a combination of an SPE seat design on the valve high pressure (HP) side and a DPE seat design on the valve low pressure (LP) side. This creates an optimal design for cryogenic service because it includes the advantages and eliminates the disadvantages of both SPE and DPE designs.

In normal conditions with the valve in its closed position, both SPE seat and DPE seat work in tandem to block in-line cryogenic flow. The Mean-Time-To-Failure (MTTF) and overall reliability of the valve are dramatically increased. In the event of build-up of cavity pressure, the SPE seat on the HP side performs exactly like a pressure relief mechanism to release excess pressure. The relief direction is always to the HP side, and not randomly directed to either side as in a DBB design.

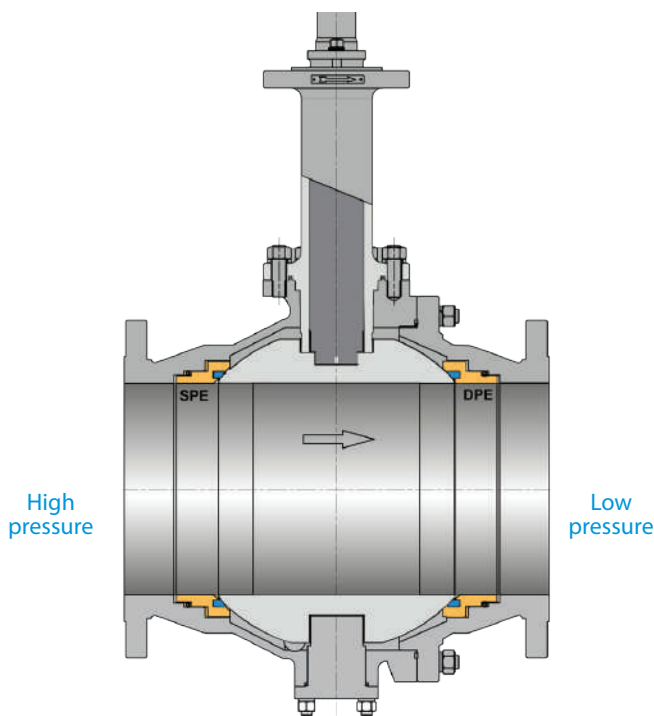

DIB-2 cryogenic valve design



# Trunnion mounted cryogenic ball valve

CT84F2, CT85F2, CT87F2 Series

Full bore, two piece, flanged class 150 / 300 / 600

NPS 2-16, DN50-DN400

## Dimensional data

CT84F2 - CLASS 150 FULL PORT TWO PIECE SERIES								
Valve size (DN/NPS)	A	B		C	D	Trim number	Weight (kg / lb)	Kv / Cv
		Short Ptn.	Long Ptn.					
DN50	49	178	-	369	92	22DD	17	402
2	1.93	7.01	-	14.53	3.62		37	465
DN80	74	203	-	415	111.5	30DD	26	1023
3	2.91	7.99	-	16.34	4.39		57	1183
DN100	100	229	-	425	125	30DD	42	1826
4	3.94	9.02	-	16.73	4.92		93	2111
DN150	150	-	394	470.5	171	40	65	4299
6	5.91	-	15.51	18.52	6.73		143	4970
DN200	201	-	457	519.5	215	48	176	7964
8	7.91	-	17.99	20.45	8.46		388	9207
DN250	252	-	533	546	248.5	60	295	12863
10	9.92	-	20.98	21.50	9.78		650	14869
DN300	303	-	610	600.5	301	60	405	18596
12	11.93	-	24.02	23.64	11.85		893	21497
DN350	334	686	-	678.8	340.5	68	624	22595
14	13.15	27.01	-	26.72	13.41		1376	26120
DN400	385	762	-	696.5	379.5	68	810	31249
16	15.16	30.00	-	27.42	14.94		1786	36123

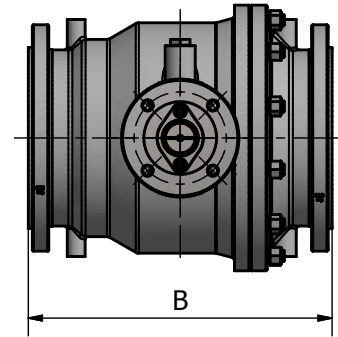
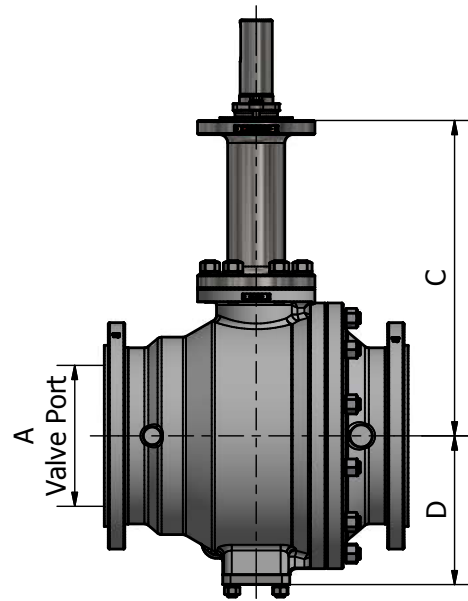

CT85F2 - CLASS 300 FULL PORT TWO PIECE SERIES								
Valve size (DN/NPS)	A	B		C	D	Trim number	Weight (kg / lb)	Kv / Cv
		Short Ptn.	Long Ptn.					
DN50	49	216	-	369	92	22DD	22	402
2	1.93	8.50	-	14.53	3.62		49	465
DN80	74	283	-	415	111.5	30DD	39	1023
3	2.91	11.14	-	16.34	4.39		86	1183
DN100	100	305	-	431	132	30DD	48	1826
4	3.94	12.01	-	16.97	5.20		106	2111
DN150	150	403	-	470.5	173.5	40	70	4299
6	5.91	15.87	-	18.52	6.83		154	4970
DN200	201	-	502	519.5	215	48	210	7964
8	7.91	-	19.76	20.45	8.46		463	9207
DN250	252	-	568	564	284.5	60	385	12863
10	9.92	-	22.36	22.20	11.20		849	14869
DN300	303	-	648	644	318.5	60	490	18596
12	11.93	-	25.51	25.35	12.54		1080	21497
DN350	334	762	-	687.5	340.5	68	860	22595
14	13.15	30.00	-	27.07	13.41		1896	26120
DN400	385	838	-	707	404.5	68	1045	31249
16	15.16	32.99	-	27.83	15.93		2304	36123

CT87F2 - CLASS 600 FULL PORT TWO PIECE SERIES								
Valve size (DN/NPS)	A	B	C	D	Trim number	Weight (kg / lb)	Kv / Cv	
								Long Ptn.
DN50	49	292	388	92	22DD	26	402	
2	1.93	11.50	15.28	3.62		57	465	
DN80	74	356	415	118.5	30DD	58	1023	
3	2.91	14.02	16.34	4.67		128	1183	
DN100	100	432	430.5	141	30DD	90	1826	
4	3.94	17.01	16.95	5.55		198	2111	
DN150	150	559	481.5	176	48	160	4299	
6	5.91	22.01	18.96	6.93		353	4970	
DN200	201	660	528.5	227	60	340	7964	
8	7.91	25.98	20.81	8.94		750	9207	
DN250	252	787	607.5	280.5	68	650	12863	
10	9.92	30.98	23.92	11.04		1433	14869	
DN300	303	838	644	318.5	82	820	18596	
12	11.93	32.99	25.35	12.54		1808	21497	
DN350	334	889	692	370.5	82	1150	22595	
14	13.15	35.00	27.24	14.59		2535	26120	
DN400	385	991	721	404.5	90	1650	31249	
16	15.16	39.02	28.39	15.93		3638	36123	

(1) For top mounting dimensions and MAST values please refer to pages 16,17

# Materials of construction

Item No.	Part description	Material specification
1	Body	ASTM A351 Gr CF8M, CF8
2	End	ASTM A351 Gr CF8M, CF8
3	Ball	ASTM A351 Gr CF8M, CF8
4	Stem	Nitronic XM-19
*4a	Stem thrust washer	PCTFE, CFT
*4b	Stem bearing	SS316 PTFE Lined
*5	Seat insert	PCTFE, CFT
*5a	Upstream seat retainer (SPE)	ASTM A351 Gr CF8M, CF8
*5b	Downstream seat retainer (DPE)	ASTM A351 Gr CF8M, CF8
*5c	Seat seal	PTFE (Lip seal)
*5d	Secondary seat seal <sup>(1)</sup>	Graphite
*5e	Coil spring	Inconel X-750
6	Body seal	Graphite, PTFE
7	Body stud	ASTM A320 Gr B8M Class 2, Gr B8 Class 2
7a	Body nut	ASTM A320 Gr 8M, Gr 8
7b	Body spring washer	SS304
*8	Stem seal	Graphite, PTFE
8a	Gland flange	ASTM A351 Gr CF8M, CF8
8b	Gland flange stud	ASTM A193 Gr B8 Class 2
*8c	Gland flange disc spring	SS304
8d	Gland flange nut	ASTM A194 Gr 8
10	Cryogenic bonnet	ASTM A351 Gr CF8M, CF8
11	Bonnet stud	ASTM A320 Gr B8M Class 2, Gr B8 Class 2
11a	Bonnet nut	ASTM A320 Gr 8M, Gr 8
11b	Bonnet spring washer	SS304
*12	Bonnet seal	Grafoil
13	Upper trunnion	ASTM A351 Gr CF8M, CF8
*13a	Upper trunnion bearing	SS316 PTFE Lined
14	Lower trunnion	ASTM A351 Gr CF8M, CF8
*14a	Lower trunnion bearing	SS316 PTFE Lined
*14b	Lower trunnion seal	Graphite, PTFE
14c	Lower trunnion stud	ASTM A320 Gr B8M Class 2, Gr B8 Class 2
14d	Lower trunnion nut	ASTM A320 Gr 8M, Gr 8
14e	Lower trunnion spring washer	SS304
*14f	Lower trunnion coil spring & plunger	Inconel X-750 & SS316
16	Antistatic plunger (not shown)	SS316
16a	Antistatic spring (not shown)	SS316
17	Valve tag (not shown)	SS304
18	Stem Key	C45
19	Vent plug	SS316, SS304
19a	Drain plug	SS316, SS304

\* Repair kit item  
 (1) Only applicable for fire safe valve

## Valve exploded view

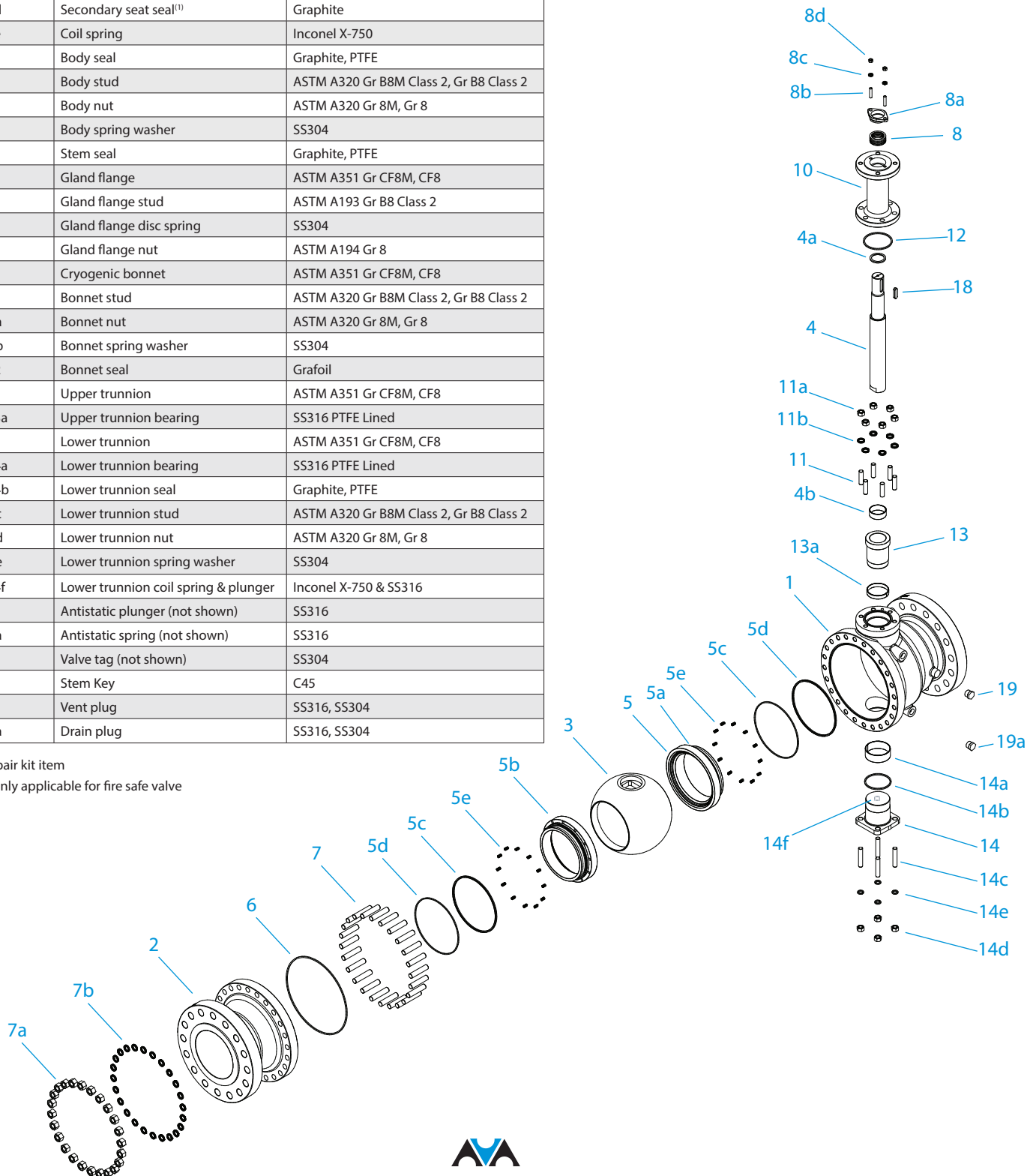

# Cryogenic floating ball valve

C87R3, C87F3 Series - 3 pcs CLASS 600  
 Full or reduced bore, three piece, flanged,  
 threaded or welded end connection  
 NPS 1/2-2 DN15-DN50

## Dimensional data

Valve size		A	B	C	D	E	F	Trim number	Weight (kg / bs)	Kv / Cv
FB	RP									
DN15	DN20	13	70	303	26	30	150	10	2.20	24
1/2	3/4	0.51	2.76	11.93	1.02	1.18	5.91		4.85	28
DN20	DN25	19	90	310	32	58	175	12.7	3.40	54
3/4	1	0.75	3.54	12.20	1.26	2.28	6.89		7.50	62
DN25	DN32	25	100	315	37	58	175	12.7	4.00	97
1	1 1/4	0.98	3.94	12.40	1.46	2.28	6.89		8.82	112
DN32	DN40	32	120	320	40	72	185	19	6.00	163
1 1/4	1 1/2	1.26	4.72	12.60	1.57	2.83	7.28		13.23	189
DN40	DN50	38	130	323	49	72	185	19	7.20	236
1 1/2	2	1.50	5.71	12.72	1.93	2.83	7.28		15.87	273

(1) For top mounting dimensions and MAST values please refer to pages 16,17

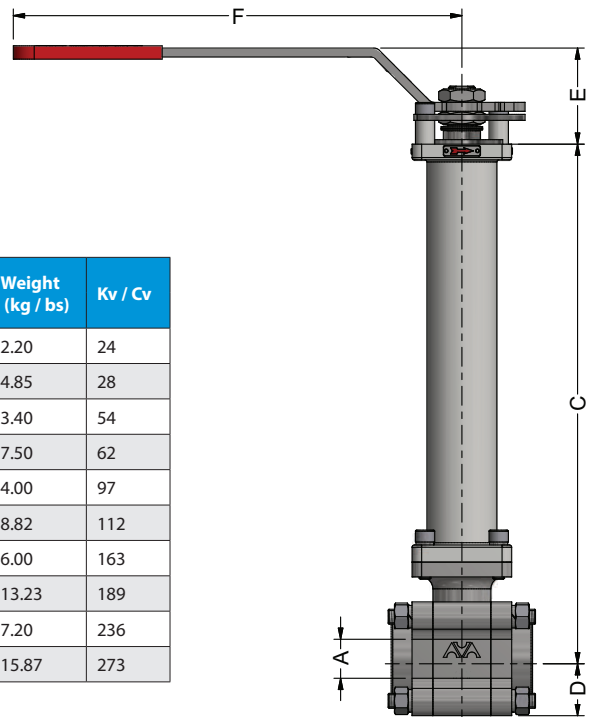

## Valve exploded view

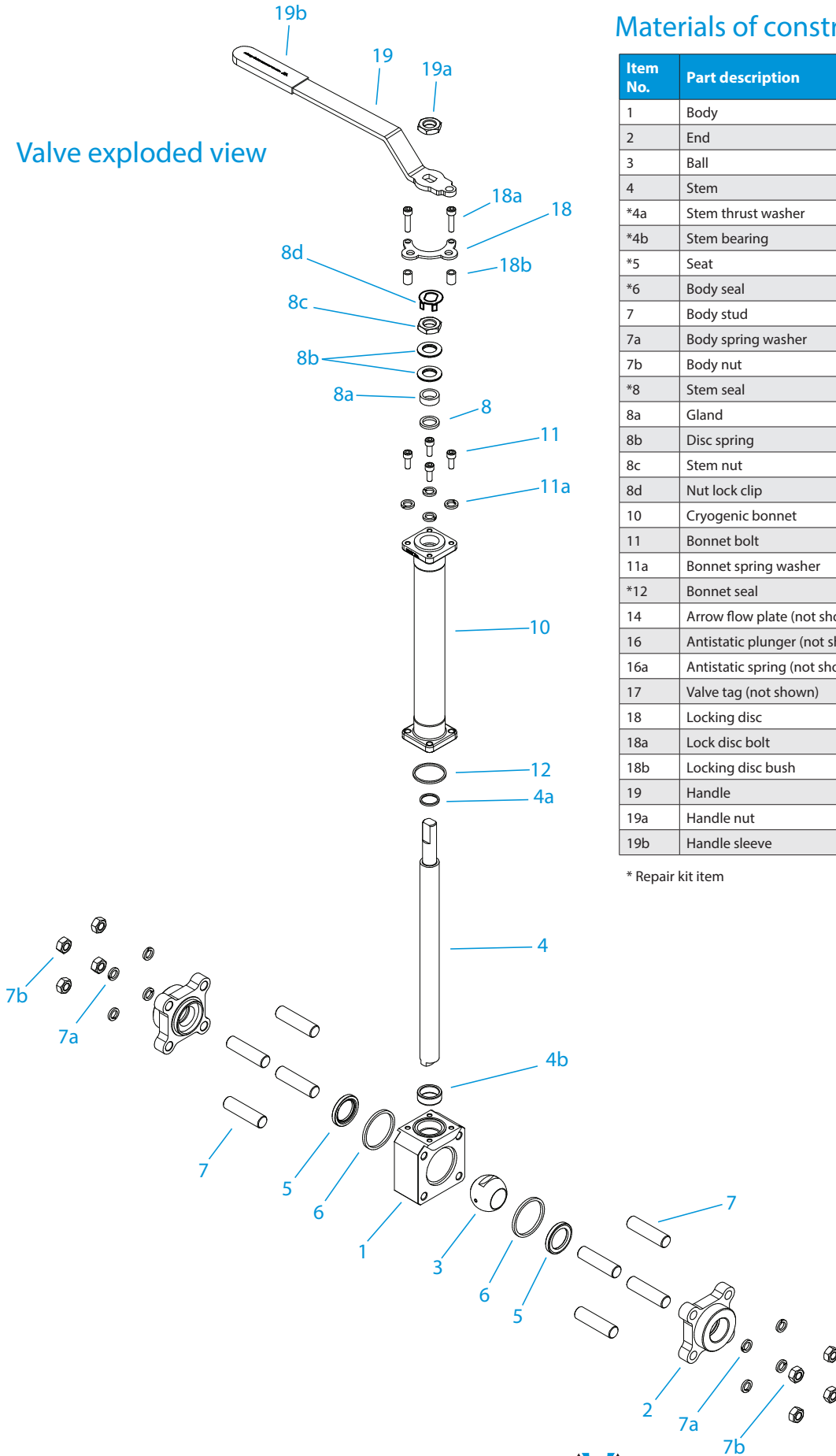

## Materials of construction

Item No.	Part description	Material specification
1	Body	ASTM A351 Gr CF8M, CF8
2	End	ASTM A351 Gr CF8M, CF8, CF3M, CF3
3	Ball	ASTM A351 Gr CF8M, CF8
4	Stem	ASTM A479 316, Nitronic XM-19
*4a	Stem thrust washer	CFT, PCTFE
*4b	Stem bearing	PTFE
*5	Seat	PCTFE, CFT
*6	Body seal	Graphite, PTFE
7	Body stud	ASTM A320 Gr B8M Class 2, Gr B8 Class2
7a	Body spring washer	SS304
7b	Body nut	ASTM A320 Gr 8M, Gr 8
*8	Stem seal	Graphite, PTFE
8a	Gland	SS304
8b	Disc spring	SS304
8c	Stem nut	ASTM A194 Gr 8
8d	Nut lock clip	SS304
10	Cryogenic bonnet	ASTM A351 Gr CF8M, CF8
11	Bonnet bolt	ASTM A320 Gr B8M Class 2, Gr B8 Class2
11a	Bonnet spring washer	SS304
*12	Bonnet seal	Graphite, PTFE
14	Arrow flow plate (not shown)	SS304
16	Antistatic plunger (not shown)	SS304
16a	Antistatic spring (not shown)	SS304
17	Valve tag (not shown)	SS304
18	Locking disc	SS304
18a	Lock disc bolt	SS304
18b	Locking disc bush	SS304
19	Handle	CS Zinc plated
19a	Handle nut	ASTM A194 Gr 8
19b	Handle sleeve	PVC

\* Repair kit item



# Cryogenic floating ball valve

C84F2, C85F2, C87F2 Series

Full bore, two piece, flange class 150 / 300 / 600

NPS 1/2-2, DN15-DN50

## Dimensional data

C84F2 - CLASS 150 FULL PORT TWO PIECE SERIES									
Valve size (DN/NPS)	A	B	C	D	E	F	Trim number	Weight (kg /lb)	Kv / Cv
DN15	13	108	295	24	30	150	10	1.60	24
1/2	0.51	4.25	11.61	0.94	1.18	5.91		3.53	28
DN20	19	117	330	27.5	58	175	12.7	2.35	54
3/4	0.75	4.61	12.99	1.08	2.28	6.89		5.18	62
DN25	25	127	304	31	58	175	12.7	3.12	97
1	0.98	5.00	11.97	1.22	2.28	6.89		6.88	112
DN32	32	140	316	38	72	185	19	4.70	163
1 1/4	1.26	5.51	12.44	1.50	2.83	7.28		10.36	189
DN40	38	165	323	46	72	185	19	5.90	236
1 1/2	1.50	6.50	12.72	1.81	2.83	7.28		13.01	273
DN50	50	178	355	56	72	307	22	10.00	419
2	1.97	7.01	13.98	2.20	2.83	12.09		22.05	484

C85F2 - CLASS 300 FULL PORT TWO PIECE SERIES									
Valve size (DN/NPS)	A	B	C	D	E	F	Trim number	Weight (kg /lb)	Kv / Cv
DN15	13	140	298	24	30	150	10	2.8	24
1/2	0.51	5.51	11.73	0.94	1.18	5.91		6.2	28
DN20	19	152	301	27.5	58	175	12.7	4.1	54
3/4	0.75	5.98	11.85	1.08	2.28	6.89		9.0	62
DN25	25	165	304	34.5	58	175	12.7	5.1	97
1	0.98	6.50	11.97	1.36	2.28	6.89		11.2	112
DN32	32	178	318	38	72	185	19	7.1	163
1 1/4	1.26	7.01	12.52	1.50	2.83	7.28		15.7	189
DN40	38	190	329	46	72	185	19	12.0	236
1 1/2	1.50	7.48	12.56	1.81	2.83	7.28		26.5	273
DN50	50	216	364	56	72	307	22	16.0	419
2	1.97	8.50	13.94	2.20	2.83	12.09		35.3	484

C87F2 - CLASS 600 FULL PORT TWO PIECE SERIES									
Valve size (DN/NPS)	A	B	C	D	E	F	Trim number	Weight (kg /lb)	Kv / Cv
DN15	13	165	304	28.5	30	150	10	3.2	24
1/2	0.51	6.50	11.97	1.12	1.18	5.91		7.1	28
DN20	19	190	304	41.5	58	175	12.7	5.0	54
3/4	0.75	7.48	11.97	1.63	2.28	6.89		11.0	62
DN25	25	216	308	47.5	58	175	12.7	6.5	97
1	0.98	8.50	12.13	1.87	2.28	6.89		14.3	112
DN32	32	229	320	40	72	185	19	9.8	163
1 1/4	1.26	9.00	12.60	1.57	2.83	7.28		21.6	189
DN40	38	241	333	62	72	185	19	14.0	236
1 1/2	1.50	9.49	13.11	2.44	2.83	7.28		30.9	273
DN50	50	292	372	76.5	100	550	22	23.0	419
2	1.97	11.50	14.65	3.01	3.94	21.65		50.7	484

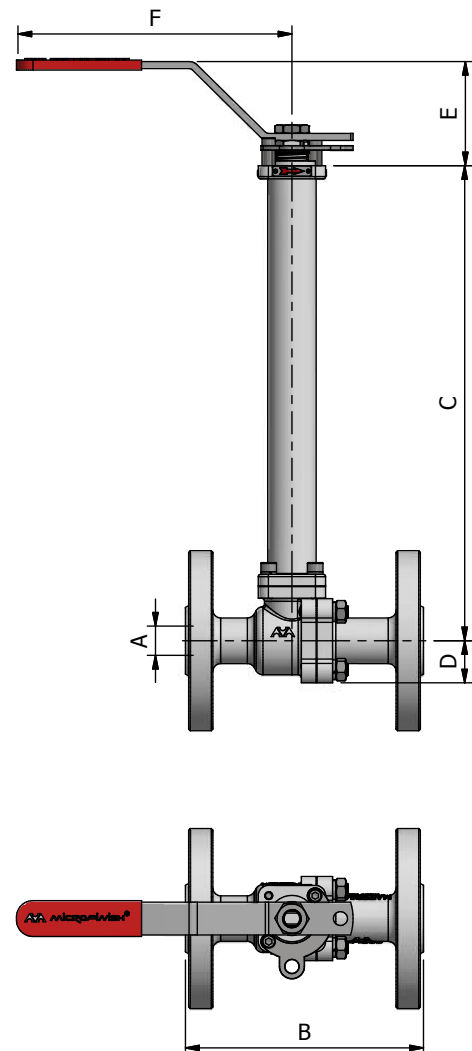

(1) For top mounting dimensions and MAST values please refer to pages 16,17

## Materials of construction

Item No.	Part description	Material specification
1	Body	ASTM A351 Gr CF8M, CF8
2	End	ASTM A351 Gr CF8M, CF8
3	Ball	ASTM A351 Gr CF8M, CF8
4	Stem	ASTM A479 316, Nitronic XM-19
*4a	Stem thrust washer	CFT, PCTFE
*4b	Stem bearing	PTFE
*5	Seat	PCTFE, CFT
*6	Body seal	Graphite, PTFE
7	Body stud	ASTM A320 Gr B8M Class 2, Gr B8 Class 2
7a	Body nut	ASTM A320 Gr 8M, Gr 8
7b	Body spring washer	SS304
*8	Stem seal	Graphite, PTFE
8a	Gland	SS304 / CF8
8b	Disc spring	SS304
8c	Stem nut	SS304
8d	Nut lock clip	SS304
10	Cryogenic bonnet	ASTM A351 Gr CF8M, CF8
11	Bonnet bolt	ASTM A320 Gr B8M Class 2
11a	Bonnet spring washer	SS304
11b	Bonnet nut	ASTM A320 Gr 8M, Gr 8
*12	Bonnet seal	Graphite, PTFE
14	Arrow flow plate (not shown)	SS304
16	Antistatic plunger (not shown)	SS316
16a	Antistatic spring (not shown)	SS316
17	Valve tag (not shown)	SS304
18	Lock disc	SS304
18a	Lock disc bolt	SS304
18b	lock disc bushing	SS304
19	Handle	CS Zinc plated
19a	Handle adaptor	CS epoxy painted
19b	Handle sleeve	PVC
19c	Adaptor bolt	CS Zinc plated
19d	Handle bolt	CS Zinc plated
19e	Handle bolt washer	CS Zinc plated

\* Repair kit item

## Valve exploded view

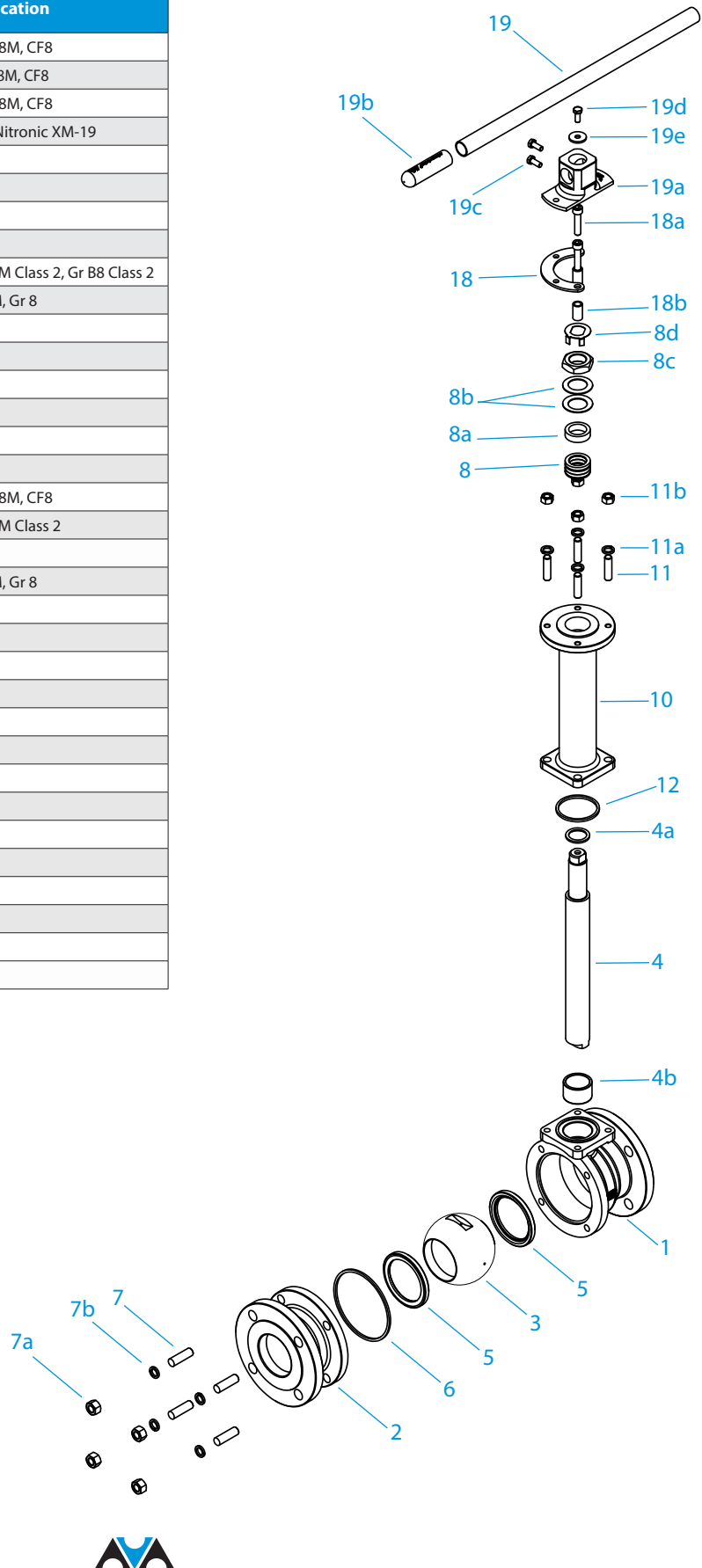

# Cryogenic floating ball valve

C84F2, C85F2, C87F2 Series

Full bore, two pieces, flange class 150 / 300 / 600

NPS 2 1/2-10, DN65-DN250

## Dimensional data

C84F2 - CLASS 150 FULL PORT TWO PIECE SERIES										
Valve size (DN/NPS)	A	B		C	D	E	F	Trim number	Weight (kg /lb)	Kv / Cv
		Short Ptn.	Long Ptn.							
DN65	65	190	-	368	79	100	550	30	16	727
2 1/2"	2.56	7.48	-	14.49	3.11	3.94	21.65		35	841
DN80	76	203	-	390	89	100	550	30	21	1023
3	2.99	7.99	-	15.35	3.50	3.94	21.65		46	1183
DN100	100	229	-	409	110	100	550	40	33	1900
4	3.94	9.02	-	16.10	4.33	3.94	21.65		73	2196
DN150	152	267	394	449	148	131	700	48	76	4357
6	5.98	10.51	15.51	17.68	5.83	5.16	27.56		168	5036
DN200	203	292	457	497	187	-	-	60	97	8043
8	7.99	11.50	17.99	19.57	7.36	-	-		214	9298
DN250	252	330	533	564	228	-	-	68	148	12863
10	9.92	12.99	20.98	22.20	8.98	-	-		326	14869

C85F2 - CLASS 300 FULL PORT TWO PIECE SERIES										
Valve size (DN/NPS)	A	B		C	D	E	F	Trim number	Weight (kg /lb)	Kv / Cv
		Short Ptn.	Long Ptn.							
DN65	65	241	-	384	89	100	550	30	22	727
2 1/2"	2.56	9.49	-	15.43	3.50	3.94	21.65		49	841
DN80	76	282	-	407	108	100	550	30	31	1023
3	2.99	11.10	-	16.02	4.25	3.94	21.65		68	1183
DN100	100	305	-	410	108	100	550	40	52	1900
4	3.94	12.01	-	16.14	4.25	3.94	21.65		115	2196
DN150	152	403	-	482	174	-	-	48	106	4357
6	5.98	15.87	-	18.98	6.85	-	-		234	5036
DN200	203	419	502	523	202	-	-	60	172	8043
8	7.99	16.50	19.76	20.59	7.95	-	-		379	9298
DN250	252	457	568	598	242	-	-	68	275	12863
10	9.92	17.99	22.36	23.54	9.53	-	-		606	14869

C87F2 - CLASS 600 FULL PORT 2 PCS SERIES										
Valve size (DN/NPS)	A	B		C	D	E	F	Trim number	Weight (kg /lb)	Kv / Cv
		Long Ptn.								
DN65	65	330	392	88.5	100	550	22	32	727	
2 1/2"	2.56	12.99	15.43	3.48	3.94	21.65		71	841	
DN80	76	356	409	98.5	-	-	30	58	1023	
3	2.99	14.02	16.10	3.88	-	-		128	1183	
DN100	102	432	432	120	-	-	30	80	1900	
4	4.02	17.01	17.01	4.72	-	-		176	2196	
DN150	150	559	501	192	-	-	48	184	4243	
6	5.91	22.01	19.72	7.56	-	-		406	4904	
DN200	201	660	552	223	-	-	60	290	7885	
8	7.91	25.98	21.73	8.73	-	-		639	9116	
DN250	252	787	622	2.68	-	-	68	476	12863	
10	9.92	30.98	24.49	10.55	-	-		1049	14869	

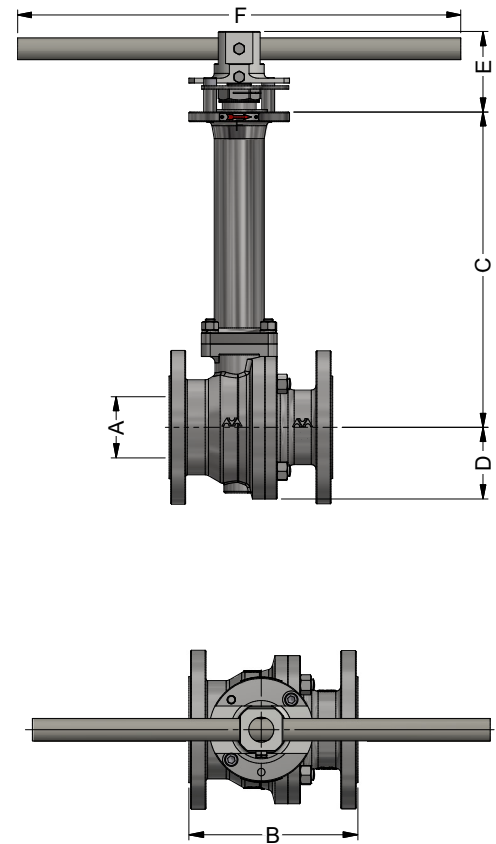

(1) For top mounting dimensions and MAST values please refer to pages 16,17



## Installation direction

Every **Microfinish** cryogenic valve includes an arrow plate attached to the valve body and to the bonnet top side. The arrow indicates the valve orientation for correct installation with the High Pressure (HP) side at its tail and the Low Pressure (LP) side at the arrow head.

The arrow direction does not always indicate the normal direction of cryogen flow; on the contrary in most applications the valve should be installed with the arrow pointing in the opposite to the normal direction of cryogen flow. To clarify this issue, the high pressure side should be specified when the flow stops and the valve is in its closed position; Although it may seem trivial, **Microfinish** has found this to be a very common error in industry which causes double the work, a waste of raw materials, and even a safety concern.

## Cryogenic bonnet inclination

The function of the bonnet of a cryogenic valve is to allow proper heat transfer, and a steep temperature gradient along the bonnet's length between cryogenic temperatures as low as  $-196^{\circ}\text{C}$  /  $-320^{\circ}\text{F}$  at the valve center line, and a temperature of around  $-10^{\circ}\text{C}$  /  $14^{\circ}\text{F}$  at the cryogenic ISO top pad. This feature allows the soft parts of the valve gland packing to remain flexible above the glass transition point. According to the BS 6364 standard a 10 inch (250 mm) cryogenic bonnet shall be installed in the vertical position or inclined up to  $45^{\circ}$  from the vertical axis. For confined spaces and systems characterized by high vibration **Microfinish** offers a 6 inch (150 mm) bonnet, not compliant with BS 6364. A cryogenic valve with 6 inch bonnet shall be installed only in the vertical position.

# Top mounting dimensions and Maximum Allowable Stem Torque (MAST)

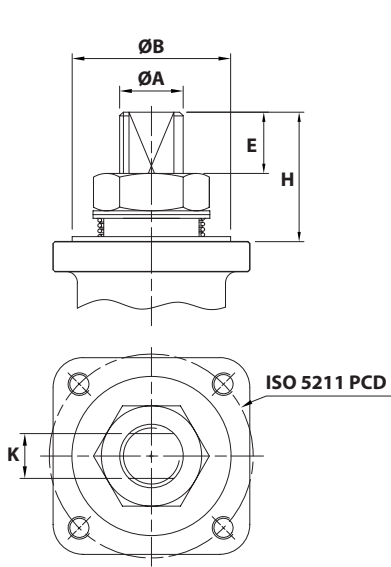

Trunnion Trim 22 - 48  
Floating ball valve Trim 10 - 48

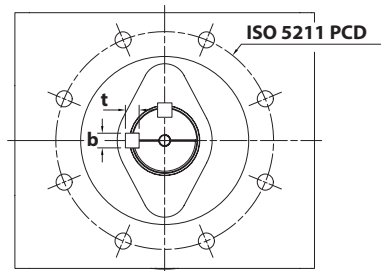
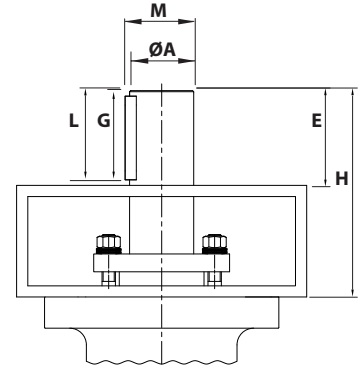

Trunnion Trim 60-105  
Floating ball valve - Trim 60, 68

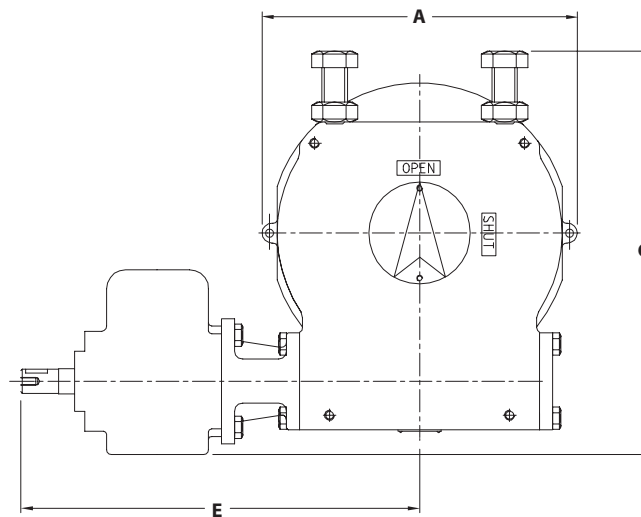

Gearbox top view

## Cryogenic trunnion mounted ball valve - top mounting dimensions and MAST values

Trim number	ISO 5211 PCD	Unit	ØA	E	G	H	K	L	M	b	t	Unit	M.A.S.T. SS316	M.A.S.T. XM-19
22	F07	mm	M20X2P	15	--	50	14	--	--	--	--	N-m	144	202
		Inch		0.591	--	1.969	0.551	--	--	--	--	lbf-in.	1275	1784
30	F10	mm	24.5	25	--	58	19	--	--	--	--	N-m	361	505
		Inch	0.965	0.984	--	2.283	0.748	--	--	--	--	lbf-in.	3195	4473
40	F12	mm	35.5	33	--	70	27	--	--	--	--	N-m	1065	1491
		Inch	1.398	1.299	--	2.756	1.063	--	--	--	--	lbf-in.	9426	13196
48	F14	mm	42	41	--	84	32	--	--	--	--	N-m	1768	2475
		Inch	1.635	1.614	--	3.307	1.259	--	--	--	--	lbf-in.	15646	21903
60	F16	mm	57.5	85	75	185	--	80	61.5	16	10	N-m	4830	6565
		Inch	2.264	3.346	2.953	7.283	--	3.150	2.421	0.630	0.394	lbf-in.	42749	58102
68	F25	mm	65.0	85	75	195	--	80	69	18	11	N-m	6896	9654
		Inch	2.559	3.346	2.953	7.677	--	3.150	2.717	0.709	0.433	lbf-in.	61035	85449
82	F25	mm	80	85	75	195	--	80	85	22	14	N-m	12641	17697
		Inch	3.150	3.346	2.953	7.677	--	3.150	3.346	0.866	0.551	lbf-in.	111882	156635
90	F30	mm	85	130	120	260	--	125	90	22	14	N-m	15483	24416
		Inch	3.346	5.118	4.724	10.236	--	4.921	3.543	0.866	0.551	lbf-in.	137036	216100
105	F35	mm	100	135	125	285	--	130	106	28	16	N-m	25797	39871
		Inch	3.937	5.315	4.921	11.220	--	5.118	4.173	1.102	0.630	lbf-in.	228323	352885

## Cryogenic floating ball valve - top mounting dimensions and MAST values

Trim number	ISO 5211	Unit	ØA	ØB	E	K	H	Unit	M.A.S.T. SS316	M.A.S.T. XM-19	
10	F03	mm	M10X1.5P	25	7	7	11	N-m	15	21	
		inch		0.984	0.276	0.276	0.433	lbf-in.	133	186	
12.7	F04	mm	M12X1.75P	30	11	8	17	N-m	24	34	
		inch		1.181	0.433	0.315	0.669	lbf-in.	212	297	
19	F05	mm	M18X1.5P	35.0	14	14	35	N-m	119	167	
		inch		1.378	0.551	0.551	1.378	lbf-in.	1053	1475	
22	F07	mm	M20X2P	55.0	15	14	50	N-m	135	189	
		inch		2.165	0.591	0.551	1.969	lbf-in.	1195	1673	
30	F10	mm	27.2	70.0	25	19	58	N-m	419	587	
		inch	1.071	2.756	33	0.748	2.283	lbf-in.	3708	5192	
40	F12	mm	35.5	85	33	27	70	N-m	1065	1491	
		inch	1.398	3.346	1.299	1.063	2.756	lbf-in.	9426	13196	
48	F14	mm	42	100	41	32	84	N-m	1768	2475	
		inch	1.653	3.937	1.614	1.259	3.307	lbf-in.	15646	21903	
60, 68	Use cryogenic trunnion mounted ball valve - top mounting dimensions and MAST values										

## Gearbox dimensions and selection

Trim number	Unit	A	C	E	Gear height	Shaft diameter	Hand wheel diameter	Drive bore diameter	Weight (kg / lb.)	Maximum input torque (Nm / lbf-in)	Maximum output torque (Nm / lbf-in)	ISO 5211 PCD
30	mm	88	116	153	62	16	250	30	3.20	44	440	F10
	Inch	3.465	4.567	6.024	2.441	0.630	9.843	1.181	7.05	389	3894	
40	mm	127	158	199	79	20	450	35.5	8.00	89	981	F12
	Inch	5.000	6.220	7.835	3.110	0.787	17.717	1.398	17.64	789	8683	
48	mm	230	249	254	107	20	550	43.5	22.00	202	3236	F14
	Inch	9.055	9.803	10.000	4.213	0.787	21.654	1.713	48.50	1790	28641	
60	mm	265	288	256	114	20	600	57.5	34.00	98	4905	F16
	Inch	10.433	11.339	10.079	4.488	0.787	23.622	2.264	74.96	868	43413	
68	mm	280	320	253	136	20	650	65	46.00	106	6379	F25
	Inch	11.024	12.598	9.961	5.354	0.787	25.591	2.559	101.41	941	56459	
82	mm	345	425	407	175	24	650	80	95.00	147	14715	F25
	Inch	13.583	16.732	16.024	6.890	0.945	25.591	3.150	209.44	1302	130239	
90	mm	345	425	407	175	24	650	85	95.00	147	14715	F30
	Inch	13.583	16.732	16.024	6.890	0.945	25.591	3.346	209.44	1302	130239	
105	mm	484	547	508	197	24	750	100	210.00	164	34335	F35
	Inch	19.055	21.535	20.000	7.756	0.945	29.528	3.937	462.97	1447	303891	



# Build your cryogenic valve code

## Trunnion mounted ball valve for cryogenic service

### BV 12" DN300 CT87F2 - 4 4 5 4 6 2 H

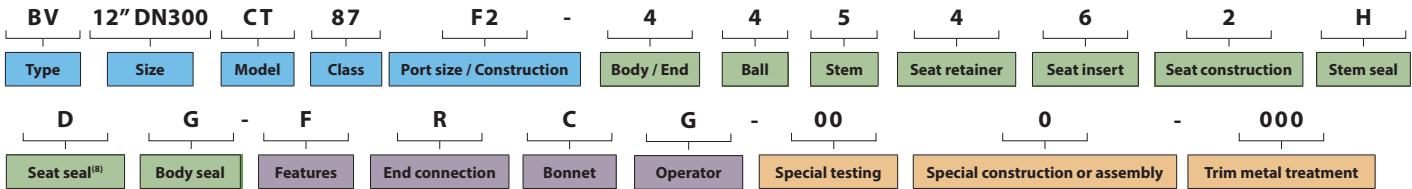

Type		Size	
BV	2"-48"	DN50-DN1200	

Model	
C	Cryogenic -200°C ≤ T ≤ +150°C -320°F ≤ T ≤ +300°F
F	Deep cryogenic -269°C ≤ T ≤ +150°C -452°F ≤ T ≤ +300°F
M	Metal seats
T	Trunnion mounted

Class	
84	#150
85	#300
87	#600
89	#900
90	#1500
91	#2500

Port size / Construction	
F2	Full / two piece
F3	Full / three piece
R2	Reduced / two piece
R3	Reduced / three piece

Body / End	
2	CF8
4	CF8M

Ball	
2	CF8 - 304
4	CF8M - 316

Stem	
5	Nitronic 50 (XM19)

Seat retainer	
2	CF8 - 304
4	CF8M - 316

Seat insert	
3	CFT (CF PTFE)
6	PCTFE
0 <sup>(6)</sup>	Metal seat

Seat construction	
0	DBB
2 <sup>(2)</sup>	DIB-2

Stem seal	
G	Graphite rings
H	Graphite Cup-n-Cone
S <sup>(4)</sup>	PTFE Cup-n-Cone
T <sup>(4)</sup>	PTFE Rings

Seat seal	
D	Lip seal
G	Graphite

Body seal	
G	Graphite
T <sup>(5)</sup>	PTFE

Features	
0	Non-Fire Safe
1	Non-Fire Safe NACE MR0175 / MR0103
F	Fire Safe to API 607 / ISO10497
G	Fire Safe to API 607 / ISO10497 and NACE MR0175 / MR0103

End connection	
A	NPT
B	BSPT
C	Socket-Weld-End (SWE)
L	BW Sch. 40S
M	BW Sch. 80
N	BW Sch. 160
R	RF Flange
S	Flat face flange
T	RTJ flange
U <sup>(5)</sup>	Extended-pups BW Sch. 10
V <sup>(5)</sup>	Extended-pups BW Sch. 40S
W <sup>(5)</sup>	Extended-pups BW Sch. 80
X <sup>(5)</sup>	Extended-pups BW Sch. 160
Y <sup>(5)</sup>	Extended-pups BW Sch. XXX

Bonnet	
C	Cryogenic bonnet BS6364 (10 inch / 250 MM)
D	Cryogenic bonnet BS6364 Cold box

Operator	
B	Bare stem
C	Lever
D	Pneumatic actuator and manual override
E	Electric actuator
G	Gear
K	Lockable gear
L	Lockable lever
P	Pneumatic actuator
S	Pneumatic actuator and partial stroke unit

Special testing			
0	None	0	None
1	Positive Material Identification (PMI)	3	Impact test @ -49°C / -56°F
2	Radiographic Test (RT)	4	Impact test @ -101°C / -150°F
3	Ultrasonic Test (UT)	5	Impact test @ -196°C / -320°F
4	Die Penetrat (DP)	F	BS6364 Cryogenic Test (CT)
5	Magnetic Particles (MP) test		

Special construction or assembly	
0	Vent & drain ports tapped and plugged; No sealant injection point;
S	No sealant; No drain; No vent

Trim metal treatment		
Ball	Seat	Stem
0	None	
E	ENP 25 micron	
F	ENP 50 micron	
N	ENP 75 micron	
H	Nitrid hardening	
S	Stellite	
T	Tungsten carbide (HVOF)	
C	Chromium carbide (HVOF)	

# Floating ball valve for cryogenic service

## BV 2" DN50 C87R3-4452GG-FACL

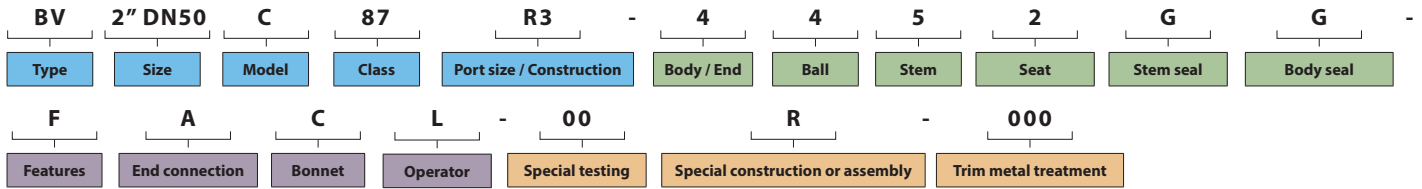

Type	Size
BV	1/2"-10" DN15-DN250

Model	
C	Cryogenic -200°C ≤ T ≤ +150°C -320°F ≤ T ≤ +300°F
F	Deep cryogenic -269°C ≤ T ≤ +150°C -452°F ≤ T ≤ +300°F
M	Metal seats

Class	
84	#150
85	#300
87	#600
89	#900
90	#1500
91	#2500

Port size / Construction	
R1	Reduced / one piece
R2	Reduced / two piece
R3	Reduced / three piece
F1	Full / one piece
F2	Full / two piece
F3	Full / three piece

Body / End	
2	CF8
4	<b>CF8M</b>
A <sup>(1)</sup>	CF8M / CF3M
B <sup>(1)</sup>	CF8 / CF3

Ball	
2	CF8 - 304
4	<b>CF8M - 316</b>

Stem	
2	SS 304
4	<b>SS 316</b>
5	<b>Nitronic (XM19)</b>

Seat	
3	<b>CFT (CF PTFE)</b>
6	<b>PCTFE</b>
Z	SS 316 - CF8M

Stem seal	
G	Graphite rings
H	Graphite Cup-n-Cone
S <sup>(4)</sup>	PTFE Cup-n-Cone
T <sup>(4)</sup>	PTFE Rings

Body seal	
G <sup>(3)</sup>	Graphite
T <sup>(4)</sup>	PTFE

Features	
0	Non-Fire Safe
1	Non-Fire Safe NACE MR0175 / MR0103
F	Fire safe to API 607/ISO10497
G	Fire safe to API 607/ISO10497 and NACE MR0175 / MR0103
U	Fire safe to API 6FA
W	Fire safe to API 6FA and NACE MR0175 / MR0103

End connection	
A	<b>NPT</b>
B	BSPT
C	Socket-Weld-End (SWE)
E	SWE x NPT
F	SWE x BSPT
G	BW Sch. 40S x NPT
H	BW Sch. 40S x BSPT
K	BW Sch. 10
L	BW Sch. 40S
M	BW Sch. 80
N	BW Sch. 160
R	<b>RF Flange</b>
S	Flat face flange
T	RTJ flange
U <sup>(5)</sup>	Extended-pups BW Sch. 10
V <sup>(5)</sup>	Extended-pups BW Sch. 40S
W <sup>(5)</sup>	Extended-pups BW Sch. 80
X <sup>(5)</sup>	Extended-pups BW Sch. 160
Y <sup>(5)</sup>	Extended-pups BW Sch. XXX
Z <sup>(5)</sup>	Extended-pups SW

Bonnet	
C	<b>Cryogenic bonnet BS6364 (10 inch / 250 mm)</b>
D	Cryogenic bonnet BS6364 Cold box
6	Cryogenic bonnet 6 inch / 150 mm

Operator	
B	Bare stem
C	Lever
D	Pneumatic actuator and manual override
E	Electric actuator
G	Gear
K	Lockable gear
L	Lockable lever
M	Dead man handle (spring/return)
P	Pneumatic actuator
S	Pneumatic actuator and partial stroke unit
V	Lockable oval handle

Special testing			
0	None	0	None
1	Positive Material Identification (PMI)	3	Impact test @ -49°C / -56°F
2	Radiographic Test (RT)	4	Impact test @ -101°C / -150°F
3	Ultrasonic Test (UT)	5	Impact test @ -196°C / -320°F
4	Die Penetrat (DP)	F	BS6364 Cryogenic Test (CT)
5	Magnetic Particles (MP) test		

Special construction or assembly	
R	Relief hole in upstream ball sphere

Trim metal treatment		
Ball	Seat	Stem
0	<b>None</b>	
E	ENP 25 micron	
F	ENP 50 micron	
N	ENP 75 micron	
H	Nitrid hardening	
S	Stellite	
T	Tungsten carbide (HVOF)	
C	Chromium carbide (HVOF)	

(1) Default combination for Stainless steel, 3 piece design and welded ends.

(2) DIB-2 is Microfinish default construction for cryogenic trunnion mounted ball valve.

(3) Graphite body seal shall be selected for fire safe valve.

(4) Do not use for fire safe valve.

(5) Default pup ends is 2 times DN or 100 mm / 4 inch (the longest between the two).

(6) Metal seat material is defined by the seat retainer material.

Note 1: In some applications the available options are limited to specific sizes.

Note 2: Cryogenic valves are cleaned for oxygen service by default.

Note 3: The gland material by default is identical to body material as a minimum.

**Note 4: Bold mark font indicates standard price list, short delivery items.**





# MICROFINISH VALVES

*Quality you can trust.*

## **India**

### **Microfinish Valves Pvt. Ltd.**

B 161-162, Industrial Estate, Gokul Road,  
Hubballi - 580030, Karnataka, India.

Tel: 91.836.2212404

Fax: 91.836.2331438

[sales@microfinishgroup.com](mailto:sales@microfinishgroup.com)

[www.microfinishgroup.com](http://www.microfinishgroup.com)

## **Americas**

### **Microfinish Valves, Inc.**

7807 Bluff Point Drive, Suite 190  
Houston, Texas 77086

Tel: 281.885.4250

Fax: 281.866.0996

[sales@microfinishvalvesinc.com](mailto:sales@microfinishvalvesinc.com)

[www.microfinishvalvesinc.com](http://www.microfinishvalvesinc.com)