

# MICROFINISH BALL VALVES

## INSTALLATION OPERATION AND MAINTENANCE MANUAL



**MICROFINISH VALVES PVT.LTD.** 

Block No.23/1K, 23/2 & 23/1B, Hubli Dharwad By-pass Road, Village Itigatti – 580114  
Taluk & Dist. Dharwad

Phone No: 91-836-2310015, 2310019 Fax No: 91-836-2310020

E-mail: sales@microfinishgroup.com Website: www.microfinishgroup.com

## INTRODUCTION

Microfinish Ball Valves have been designed and manufactured to give you long, excellent and trouble free service.

This manual provides you with all the relevant information to install, operate and maintain the valve for long trouble free life. **Please note that all the drawings provided in this manual are typical views.**

### 1.0 PRIOR TO INSTALLATION

- 1.1. On receipt of material check for any damage during transportation.
- 1.2. Wrapping and protection applied should be left in place until the valve is installed.
- 1.3. If the valves are left exposed, they should be protected against entry of foreign material in the valve parts.
- 1.4. Flush the pipe clean before mounting the valve in the pipeline. Impurities such as sand and parts of welding electrodes could damage the ball surface and the seats.
- 1.5. If the valves are stored for a long time, they should be cleaned, lubricated and tested prior to installation. It is advisable to store the valve in full open position.
- 1.6. In Lever operated valve, the position of Handle is an indication of whether the valve is open or closed. When the Handle is aligned with axis of the pipe the valve is **open**. When it is Perpendicular to the pipe, the valve is **closed**.

### 2.0 INSTALLATION

- 2.1 The valve may be installed in any position, however avoid stem position downwards. It is recommended to mount the valve having stem in horizontal position.
- 2.2 Valve should not carry the weight of the piping. Proper support of the pipeline will minimize strain on the valve caused by shock in the pipe system. The valve can be supported by its body with pipe clamps and supports. Do not fasten supporting structure to the valve flanges.
- 2.3 Do not attempt to correct pipe misalignment by means of flange bolts.
- 2.4 Do not allow the valves to carry the weight of pipeline to avoid distortion and jamming.
- 2.5 If necessary, tighten the gland packing uniformly during the trial operation of the valve.
- 2.6 A qualified welder must perform all welding operations and the welding procedure shall be in accordance with ASME Boiler & Pressure Vessel Code Section IX.
- 2.7 When mounting the screwed end, butt weld end, socket weld end and flanged end type valves the following respective procedures must be followed, for better performance.
- 2.8 **SCREWED END VALVE INSTALLATION**

2.8a Clean both the mating parts before assembly.

2.8b Sealant if necessary should be applied only to the pipe or male threads.

2.8c Use correct size wrenches with flat jaws on hexagon or octagon ends.

2.8d Do not use undersized threads on section of pipe where the valves are to be installed.

## **2.9 BUTT WELD END VALVE INSTALLATION**

2.9a Keep the valve in 'Full Open' position.

2.9b Space the joint apart, co-axially with a 2 to 3 mm gap.

2.9c Use an internal welding backing ring where practical.

2.9d After finishing the welding operation clean the pipeline and valve parts by flushing or pigging to remove the impurities formed during welding.

2.9e Do not allow rapid application of excess welding material.

2.9f Do not allow the temperature of valve body seat area to exceed 120° C (248° F) to prevent seat and seal damage.

2.9g When butt weld end valves are purchased with no extended nipple, before welding, remove the central body assembly along with ball and seats, place a spacer of same dimensions and then weld the ends.

## **2.10 SOCKET WELD END VALVE INSTALLATION**

2.10a Keep the valve in 'Full Open' position.

2.10b First insert the pipe to full depth of socket then pull out about 1.5mm and weld.

2.10c Provide adequate support to the pipe on each side or to the valve prior to welding.

2.10d Weld each end of the valve with a continuous bead. The welding rod should not exceed 3.2 mm diameter.

2.10e Remove the spacer and reassemble the valve body assembly when the system cools down to ambient temperature.

2.10f Do not allow the temperature of valve body seat area to exceed 120° C (248° F) to prevent seat and seal damage.

2.10g When socket end valves are purchased with no extended nipple, before welding, remove the central body assembly along with ball and seats, place a spacer of same dimensions and then weld the ends.

## **2.11 FLANGED END VALVE INSTALLATION**

2.11a Be sure that flange gaskets and fasteners are suitable for the operating conditions.

2.11b Insert the valve (fully open position) along with suitable gasket between the mating flanges, align the flange boltholes & hold it in place.

2.11c Hold the nuts first on backside of the valve flange and then insert the bolts.

2.11d Tighten all the bolts to finger tight.

2.11e Use two spanners to tighten the joint, in the sequence as shown in Figure

### BOLTING SEQUENCE CHART

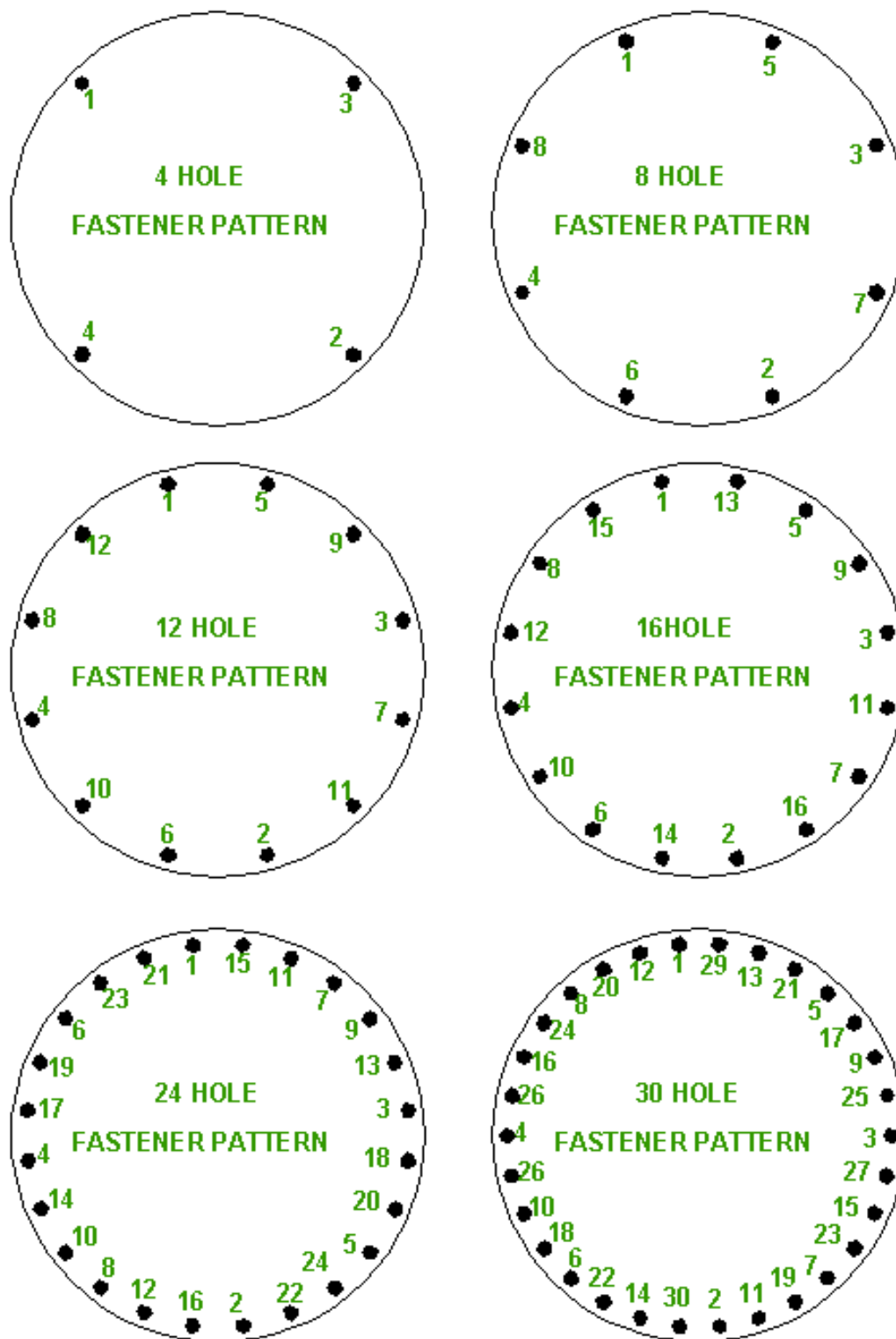

FIGURE-1

## TIGHTENING TORQUES FOR FASTENERS

Thread size x Pitch	Tightening Torque for lubricated fasteners		Tightening Torque for Dry fasteners	
	N-m	<i>lbf-in</i>	N-m	<i>lbf-in</i>
M5X0.8	3 to 4	27 to 35	4 to 5	35 to 44
M6X1	5 to 6	44 to 53	7 to 9	62 to 80
M8X1.25	11 to 14	97 to 124	16 to 20	142 to 177
M10X1.5	22 to 24	195 to 212	30 to 33	266 to 292
M12X1.75	37 to 39	327 to 345	51 to 54	451 to 478
M14X2	55 to 57	487 to 504	81 to 85	717 to 752
M16X2	83 to 87	735 to 770	123 to 130	1089 to 1151
M20X2.5	165 to 170	1460 to 1505	240 to 250	2124 to 2213
M24X3	275 to 290	2434 to 2567	410 to 430	3629 to 3806
M30X3	555 to 585	4912 to 5178	825 to 870	7302 to 7700
M30X3.5	540 to 570	4779 to 5045	800 to 840	7081 to 7435
M33x3	745 to 785	6594 to 6948	1115 to 1170	9869 to 10355
M33X3.5	740 to 775	6550 to 6859	1100 to 1155	9736 to 10223
M36X3	975 to 1025	8629 to 9072	1460 to 1535	12922 to 13586
M36X4	935 to 985	8275 to 8718	1390 to 1455	12303 to 12878
M39X3	1260 to 1325	11152 to 11727	1890 to 1985	16728 to 17569
M42X3	1570 to 1650	13896 to 14604	2360 to 2475	20888 to 21906
M42X4.5	1490 to 1560	13188 to 13807	2210 to 2320	19560 to 20534
M48X3	2380 to 2500	21065 to 22127	3585 to 3765	31730 to 33323
M48X5	2220 to 2335	19649 to 20666	3305 to 3470	29252 to 30712
M52X3	3020 to 3170	26729 to 28057	4555 to 4785	40315 to 42351
M52X4	2930 to 3000	25933 to 26552	4395 to 4615	38899 to 40846
M56X3	3785 to 3975	33500 to 35182	5610 to 5890	49653 to 52131
M56X4	3735 to 3920	33058 to 34695	5725 to 6010	50671 to 53193
M60X3	4675 to 4910	41377 to 43457	6965 to 7310	61645 to 64699
M60X4	4625 to 4860	40935 to 43015	7070 to 7425	62575 to 65717
M64X3	5690 to 5975	50361 to 52883	8300 to 8715	73461 to 77134
M64X4	5510 to 5785	48768 to 51202	8615 to 9050	76249 to 80099
M72X3	8145 to 8550	72089 to 75674	12350 to 12970	109307 to 114794
M80x3	10700 to 11235	94703 to 99438	16240 to 17050	143736 to 150905

### 3.0 OPERATION AND MAINTENANCE

- 3.1 Flush the pipeline carefully once more when the valves are mounted to remove all the possible impurities. Before flushing keep the valve open fully.
- 3.2 Valves should be opened and closed slowly to avoid hammering effect on the valve and pipeline.
- 3.3 Valve should be "fully opened" or "fully closed" to prevent damage to the seat and ball caused by wire drawing.
- 3.4 If valve is intended for on-off service only, it should not be used for throttling services.
- 3.5 If stem leak develops, tighten the gland nut until leakage has been stopped. If the stem leak cannot be stopped then replacement of stem packing is necessary.
- 3.6 If a through leak occurs, ensure that the valve is fully closed. Don't use extra leverage or extra force on the stem to prevent leakage. If leakage persists, replacement of seats is necessary.
- 3.7 After a long service life, when through valve leakage is observed, the seats can be interchanged.
- 3.8 The ball valve needs no regular maintenance or lubrication.
- 3.9 Replacement of stem packing:

When replacing the packing, be sure that the valve is not under pressure. Remove all accessories including actuator to give access to the packing. After loosening and removing the gland nut, the packing can be removed by means of a hooked wire.
- 3.10 Do not try to correct the through valve leakage by giving packing pieces behind the seat to make it tight. Instead replace the seat.
- 3.11 If a body seal leak develops, do not over tighten the body end cover studs and nuts. This may damage the valve. Instead body seal should be removed and replaced by new one.
- 3.12 **Sealant Injection feature in Trunnion Mounted Ball Valves** : Secondary sealant injection system is used only when damage has been caused to the seat rings or stem seals by the hard particles or dirt in the process media and a temporary tight shut off is required for maintenance or other purpose. Use standard grades of the valve sealants, which are suitable for the media in the valve. Sealant is to be pushed with a hand pump on the seat surface through the sealant injection port provided on the valve body and stem housing. Prior to injecting sealant, flush the sealant port with suitable valve cleaner. This will purge old sealant and debris if any, from the valve seats.

Procedure for emergency sealant injection.

**Note:** Sealant injection is to be carried out only if the valve seats or stem packing are leaking.

Trunnion mounted pipeline valves of sizes 6" NB and above are provided with two sealant injection ports on the body/body adapter for individual seats and one sealant injection port on the stem housing. Each port provided on the body provides sealant

entry to the valve seats. The port provided on the stem housing provides sealant entry to the stem sealing area. The ports are fitted with double-check one piece fitting.

**Injecting Handgun: Sealant** is injected by connecting the outlet fitting of the handgun to the sealant injection port.

Sealant should be injected only when the valve is in closed position to ensure effective sealing of damaged seat.

Refer sealant injection fitting arrangement is shown in Figure No. 01. Slide the giant button head coupler which is integral with the hose of sealant injection gun, over a double - check one-piece fitting. Now the arrangement is ready for injection of the sealant.

After the completion of sealant Injection operation, slide away the giant button head coupler, which is integral with the hose of sealant Injection gun from the double-check one piece fitting.

**FIGURE : 01 Sealant Injection Fitting Arrangement**

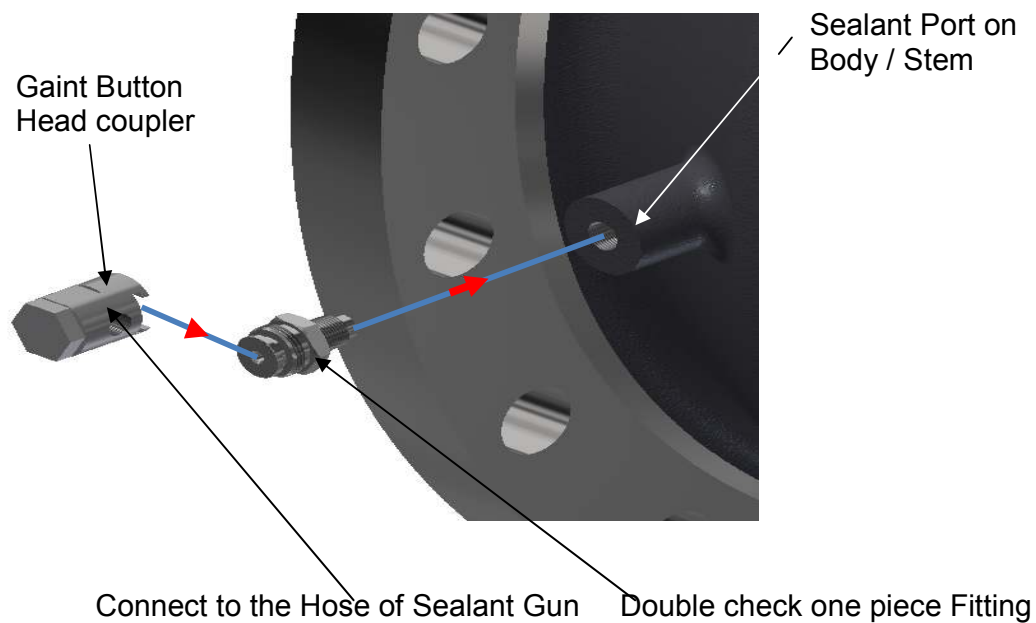

**CAUTION!**

**Injection Pressure;**

1. Min. injection pressure shall be 1.1 times the actual working line pressure.
2. Max. injection pressure shall be 1.5 times the actual working line pressure but should not exceed the Maximum Cold Working Pressure for the body/bonnet material.

Same is applicable when the sealant extension lines are provided.

**3.13 Stem packing adjustment;**

- a. Microfinish valves include the feature of an externally adjustable stem seal in the event there is leakage experienced from the stem area.

- b. If possible, relieve any pressure within the valve during the adjustment process. If this is not possible, it is still safe to perform this adjustment on a valve in the field.
- c. Operate the valve once in the No load condition.
- d. Loose the Gland Nut / Chuck Nut for 2 rounds.
- e. Operate the valve for 3 times.
- f. Tight the Gland Nut / Chuck Nut as per Table (01) column “X”.
- g. Again loose the Gland Nut / Chuck Nut.
- h. Operate the valve for 3 times.
- i. Retighten the Gland Nut / Chuck Nut as per Table (01) column “Y”.
- j. Operate the valve for 3 times.
- k. Record the No load torque.
- l. If this first action has not stopped the leak, repeat steps “ d ” to “ j ”. Only perform this adjustment action a maximum of 3 times. If the leakage has not stopped after three attempts, stop the test as further attempts could be detrimental to elements of the stem packing system.

<b>BALL VALVE CHECK NUT TIGHTENING TORQUE</b>				
<b>(Nm)</b>				
<b>CHECK NUT SIZE</b>	<b>GRAPHITE</b>		<b>PTFE</b>	
	<b>X</b>	<b>Y</b>	<b>X</b>	<b>Y</b>
<b>M10x1.5</b>	<b>10</b>	<b>5</b>	<b>9</b>	<b>5</b>
<b>M12x1.25</b>	<b>15</b>	<b>7</b>	<b>13</b>	<b>5</b>
<b>M18x1.5</b>	<b>19</b>	<b>11</b>	<b>17</b>	<b>11</b>
<b>M22x2</b>	<b>22</b>	<b>19</b>	<b>20</b>	<b>15</b>
<b>M30x2</b>	<b>29</b>	<b>19</b>	<b>27</b>	<b>18</b>
<b>M40x2</b>	<b>34</b>	<b>22</b>	<b>32</b>	<b>20</b>
<b>M48x2</b>	<b>60</b>	<b>38</b>	<b>40</b>	<b>50</b>
<b>M60x2</b>	<b>70</b>	<b>47</b>	<b>90</b>	<b>70</b>
<b>M68x2</b>	<b>80</b>	<b>70</b>	<b>120</b>	<b>90</b>
<b>M74x2</b>	<b>90</b>	<b>82</b>	<b>140</b>	<b>100</b>

Table No. 01 Check Nut Tightening Torque

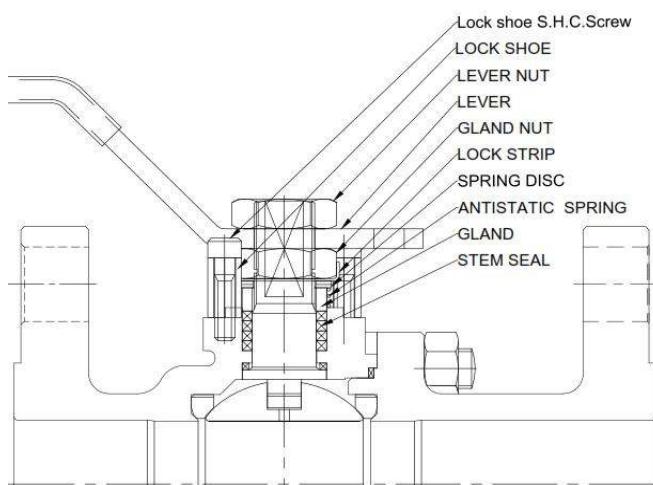

For smaller valves with a double nut design, the Gland nut is held in place by a locking strip. The adjustment of the stem seal to tighten the packing cannot be carried out while this locking clip is firmly in place. It first needs to be loosened by pulling back the tabs from the nut with a flathead screwdriver, so the nut can be rotated and reset the stem seal. When the action is complete, you need to re-secure the locking strip to the nut by pushing back up the tabs

## 4.0 DISASSEMBLY

For your safety and protection, it is important that the following precautions be taken prior to removing the valve from service or before any disassembly of the valve.

### 4.1 DISASSEMBLY FROM PIPE LINE

- 4.1a Keep hands out, since remotely actuated valves could close at any time. Disconnect all auxiliary piping of jackets and pneumatic or electric connections.
- 4.1b Wear any protective clothing or equipment normally required when working with media involved.
- 4.1c De-pressurize all the lines and drain the system fluid. Cycle the valve several times to relieve any pressure still inside the valve.
- 4.1d Keep the valve in full open position. Remove the valve and place it on a level surface in vertical position.

### **WARNING!**

**VALVES SHALL NOT BE DISMANTLED IN CLOSED POSITION**

### 4.2 DISASSEMBLY OF THE FLOATING VALVE (REFER FIGURE-2)

- 4.2a Flush the valve to remove the residuals in the valve.
- 4.2b Support the valve on a platform.
- 4.2c Remove all accessories if fitted and also adapter, lever or gear operator.
- 4.2d Remove check nut / gland nut, spring, locking plate and gland.
- 4.2e Unscrew the body end connection studs and separate the body and end pieces/tail piece.
- 4.2f Place the disassembled parts on clean wooden or cardboard surface. Do not keep ball and seats on cement or metal surfaces to avoid damage.
- 4.2g Take out the seat rings and body seal. Body seal to be replaced during re-assembly.
- 4.2h Keep the valve in CLOSED position and remove the ball.
- 4.2i Push the stem into the body cavity and then takeout through the end port. Remove the stem washer and stem seal.
- 4.2j Clean all parts carefully. If necessary use suitable solvent.
- 4.2k Check all the sealing surfaces and parts for damage or uneven wear. Minor scratches or flashes on the ball surface can be removed using a fine abrasive cloth.
- 4.2l Check the condition of the stem.

### **4.3 DISASSEMBLY OF TRUNNION MOUNTED VALVE – 2PC**

(REFER FIGURE-3 and 4)

4.3a Follow the points in clause 4.2a to 4.2c

4.3b Remove lever / adapter or gear operator and bracket.

4.3c Remove check nut, spring disc, gland and anti-static spring.

4.3d Remove stuffing box, stuffing bearing and stuffing box seal.

4.3e Pull the stem from top and take out. Remove anti-static spring, stem washer and stem seals.

4.3f Remove trunnion and trunnion seal.

4.3g Unscrew the body end connection studs and separate the body and tailpiece.

4.3h Remove seat retainer from tailpiece and seat springs.

4.3g Remove the ball from body and also remove trunnion bearing and thrust washer.

4.3h Remove seat retainer from body and springs.

4.3i Place all parts on clean soft surface. Do not keep the parts on cement or metal surfaces to avoid damage.

4.3j Clean all the parts carefully. If necessary use suitable solvent.

4.3k Check all the sealing surfaces and parts for damage or uneven wear. Minor scratches or flashes on the ball surface can be removed using a fine abrasive cloth.

4.3l Check for the wear or any damage at all the sealing area of stem, ball, seat, bearings and stuffing box bore. Correct / replace the damaged parts if necessary.

### **4.4 DISASSEMBLY OF TRUNNION MOUNTED VALVE - 3PC.**

(REFER FIGURE-05)

4.4a Follow the points in clause 4.3a to 4.3c

4.4b Remove lever / adapter or gear operator and bracket.

4.4c Remove gland flange.

4.4d Remove stuffing box, stuffing bearing and stuffing box seal.

4.4e Push the stem from top and take out from bottom. Remove anti-static spring, stem washer and stem seals.

4.4f Remove ball support bottom plate, ball support washer and ball bearing.

4.4g Unscrew the body end connection studs and separate the body and both tailpieces.

- 4.4h Remove seat holder & seat retainer from tailpiece.
- 4.4i Remove the coil springs.
- 4.4j Remove the ball from body.
- 4.4k Place all parts on clean soft surface. Do not keep the parts on cement or metal surfaces to avoid damage.
- 4.4l Clean all the parts carefully. If necessary use suitable solvent.
- 4.4m Check all the sealing surfaces and parts for damage or uneven wear. Minor scratches or flashes on the ball surface can be removed using a fine abrasive cloth.
- 4.4n Check for the wear or any damage at all the sealing area of stem, ball, seat, bearings and stuffing box bore. Correct / replace the damaged parts if necessary.

## 5.0 ASSEMBLY

Using the parts contained in complete repair kit, reverse the disassembly procedure. Never reuse Packing, Body Seals, Stem Seal, Stem Washer and dispose the material as per the local government rules in such manner they could not affect the environment.

In case of damage / wear / corrosion to the parts of the valve, they need to be replaced during re-assembly and handover the damaged parts to authorized agency for reuse or dispose, so that damaged parts could not affect the environment.

When the valve is declared as scrap handover the valve to authorized agency for reuse or dispose, so that scrapped valve could not affect the environment.

# FLOATING BALL VALVE

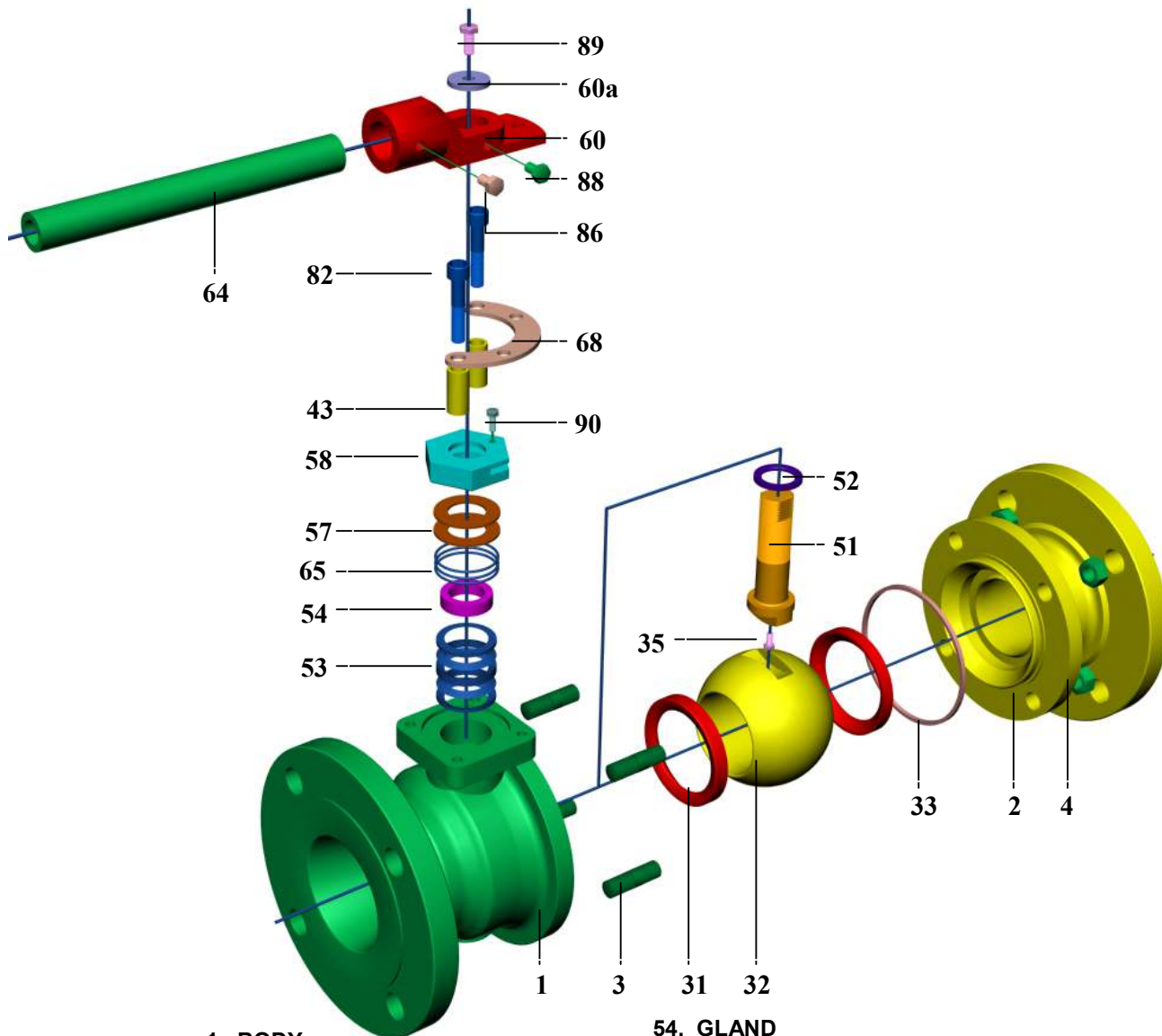

- 1. BODY
- 2. TAILPIECE
- 3. STUD
- 4. NUT
- 31. SEAT \*
- 32. BALL
- 33. BODY SEAL \*
- 35. ANTISTATIC PLUNGER
- 43. BUSH
- 51. STEM
- 52. STEM WASHER \*
- 53. STEM SEAL \*

- 54. GLAND
- 57. SPRING DISC \*
- 58. CHECK NUT
- 60. LEVER ADAPTER
- 60a. LEVER ADAPTER WASHER
- 64. ADAPTER PIPE
- 65. ANTISTATIC SPRING
- 68. LOCK SHOE
- 82. LOCK SHOE S.H.C SCREW
- 86. ADAPTER PIPE BOLT
- 88. ADAPTER BOLT
- 89. STEM BOLT
- 90. CHECK NUT BOLT

FIGURE:02

# TRUNNION MOUNTED BALL VALVE

ANSI PRESSURE CLASS 150 & 300

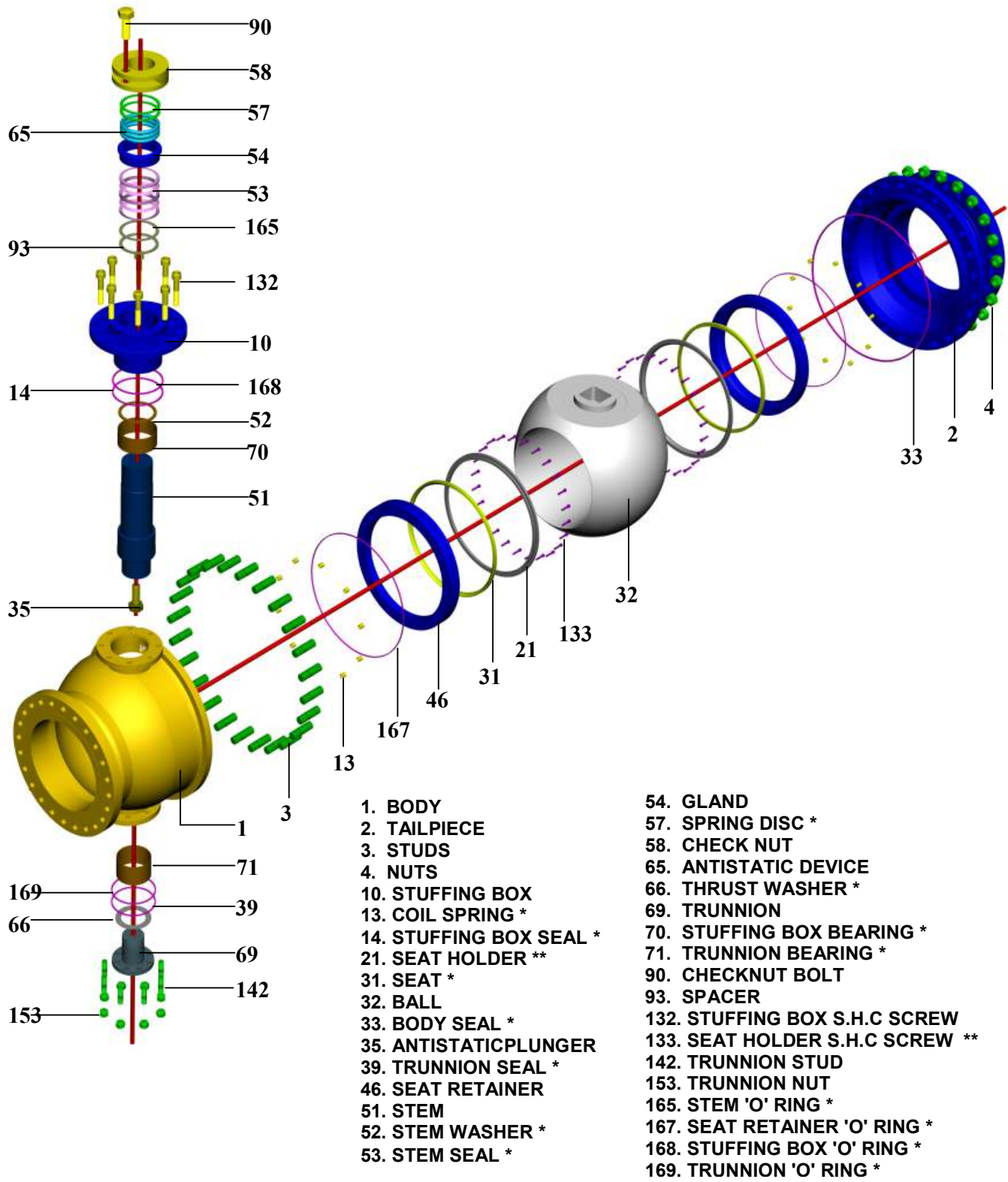

\* Recommended Spares

\*\* Applicable for sizes 12" & above.

FIGURE : 03

# TRUNNION MOUNTED BALL VALVE

ANSI PRESSURE CLASS 600 & ABOVE

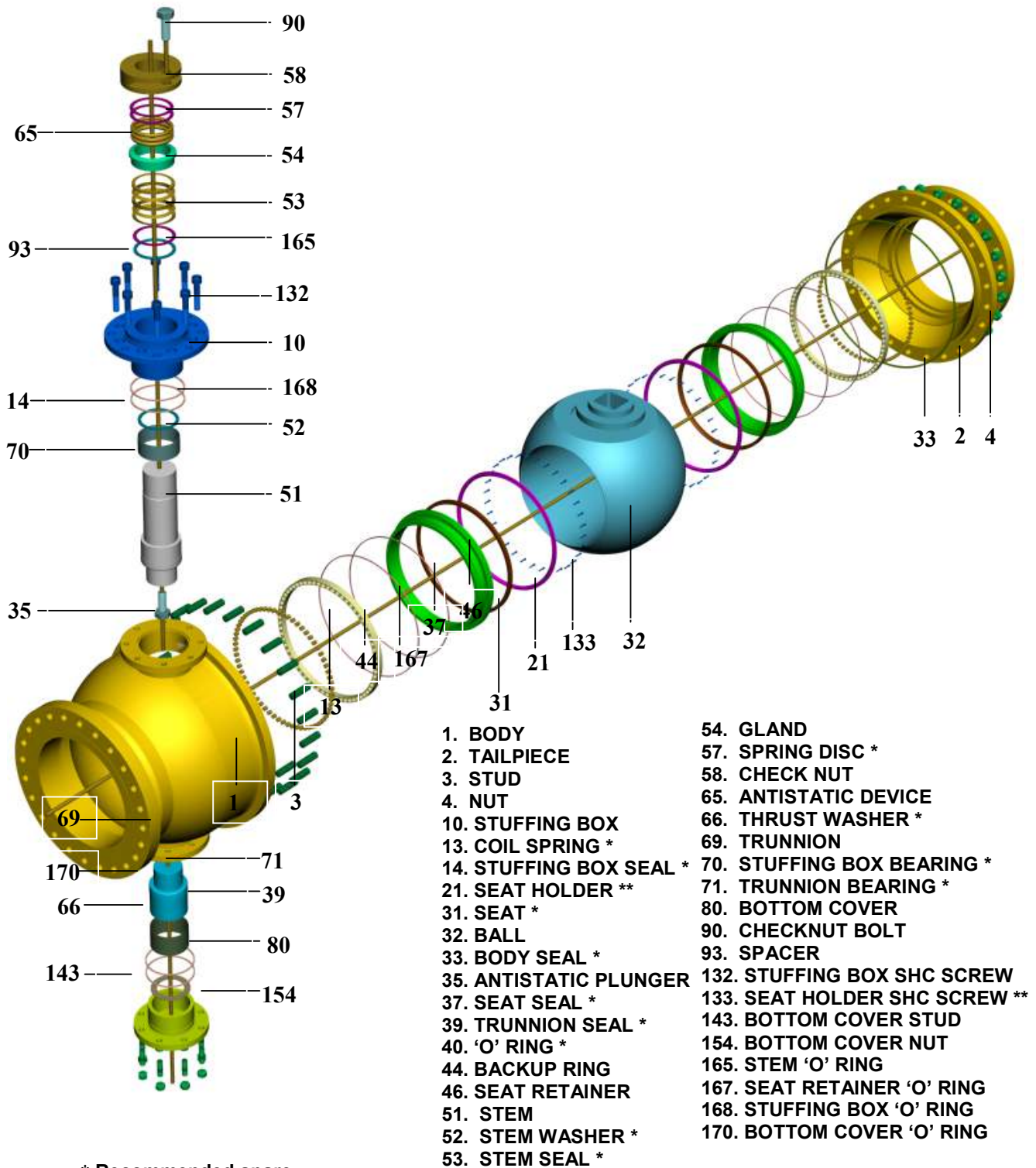

\* Recommended spare

\*\* Applicable for sizes 12" & above.

FIGURE : 04

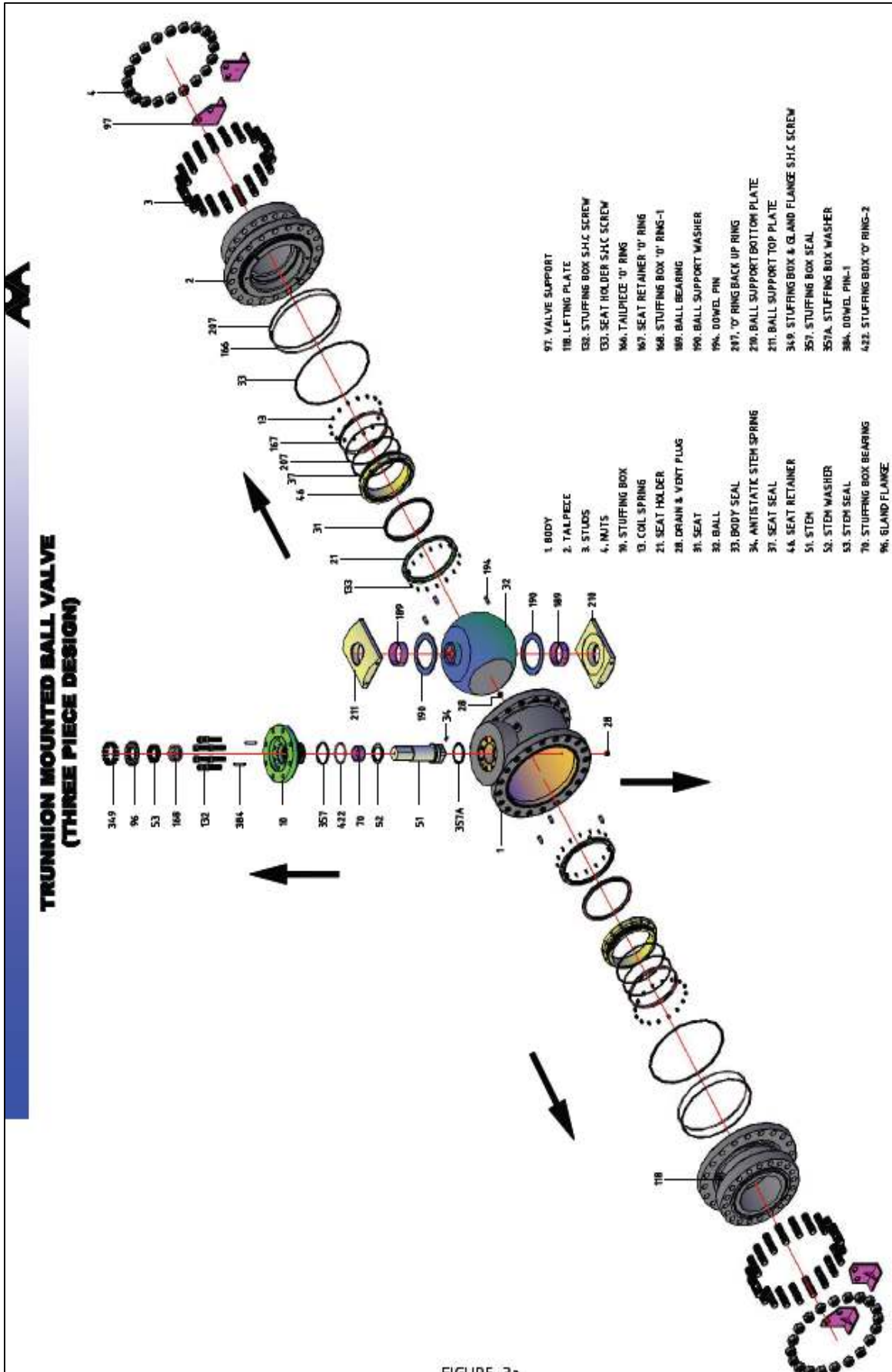





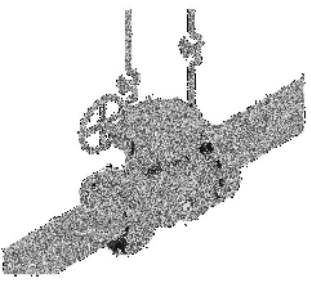

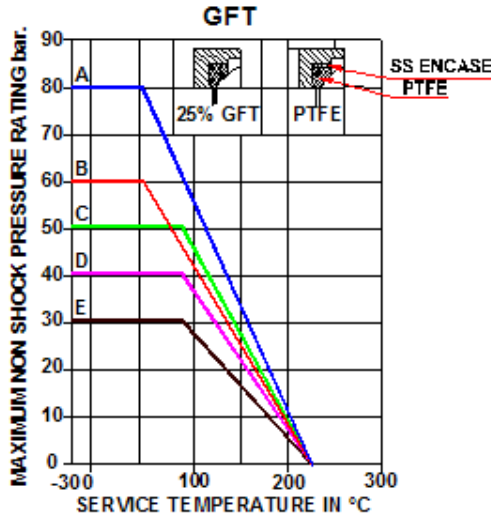

FIGURE 35

	
Way of Hosting the Ball Valve	Avoid this way of Hosting the Ball Valve
	
Way of Hosting the Ball Valve	Avoid this way of Hosting the Ball Valve
	
Valve ready for Disassembling supported on Platform	Way of supporting the Ball Valve
	
Way of supporting the Ball Valve	Way of supporting the Ball Valve

# PRESSURE - TEMPERATURE RATINGS FOR COMMON SEAT MATERIALS



SEAT SYMBOL	NOMINAL VALVE SIZE (mm)		
	PTFE & GFT		CFT
	FB	RB	RB + FB
A	08 to 20	08 to 25	08 to 50
B	25 to 65	32 to 80	65 to 100
C	80 to 100	100 to 150	150
D	150	200 to 250	200 to 300
E	200 to 400	300 to 400	--

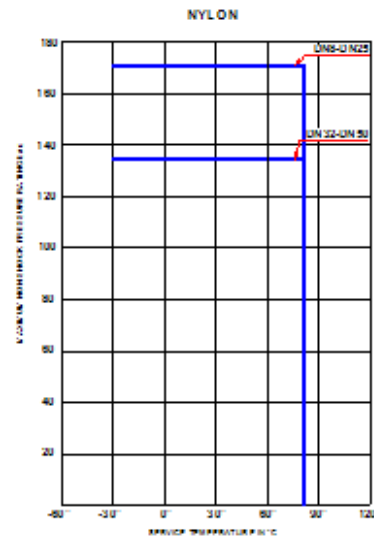
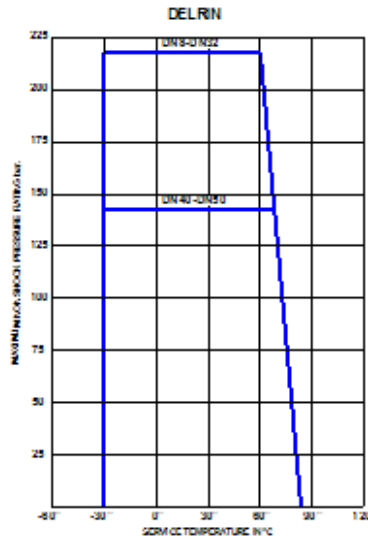
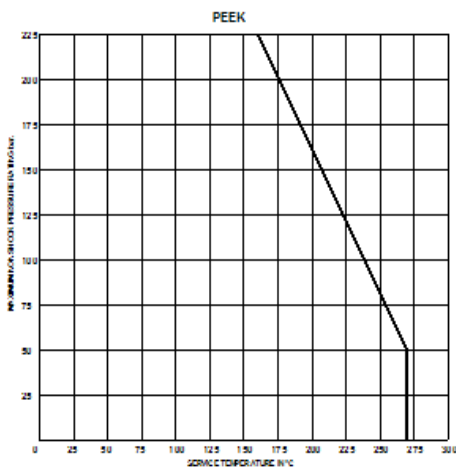
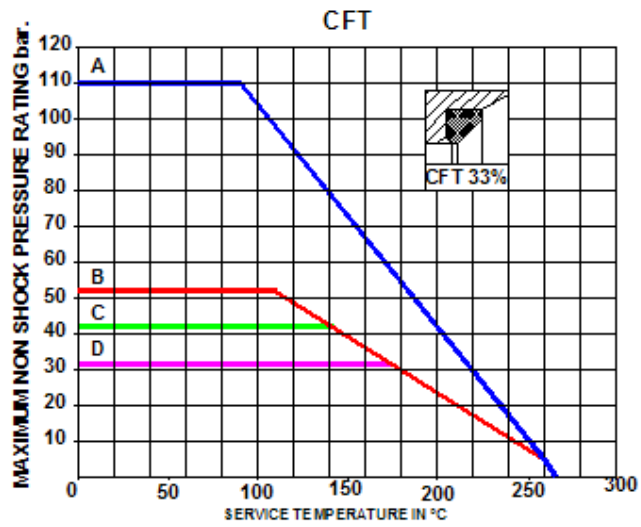
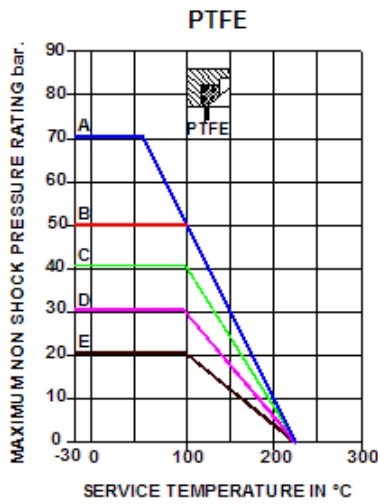

## TROUBLESHOOTING

Sl.No.	Nature of Defect	Cause	Remedy
1	Seat Leakage	<ol style="list-style-type: none"> <li>1. Damage of Seat due to presence of foreign particles.</li> <li>2. Damage of 'O' Ring at the seat/retainer.</li> <li>3. Damage of seat in weld end valves due to improper precautions.</li> <li>4. Damage of seat at high temperature.</li> <li>5. Improper closing of actuator operated valves.</li> <li>6. Damage of seat due to rust at body of seat retainer.</li> </ol>	<p>Dismantle, clean &amp; replace by new seats</p> <p>Dismantle, clean &amp; replace by new 'O' Rings</p> <p>Suggest following right steps as per IOM manual.</p> <p>Check for suitability of seat material and design.</p> <p>Ensure correct closing of actuator.</p> <p>Dismantle, clean &amp; reassemble/replace.</p>
2	Gland Leakage	<ol style="list-style-type: none"> <li>1. Loosening of check nut or locking bolt.</li> <li>2. Damage of stem seal/stem washer</li> <li>3. Misalignment of actuator, bracket &amp; stem.</li> </ol>	<p>Tighten the check nut &amp; locking bolts</p> <p>Replace the stem seal/stem washer.</p> <p>Ensure correct alignment.</p>
3	Body Seal Leakage	<ol style="list-style-type: none"> <li>1. Improper tightening of Body bolting.</li> <li>2. Improper precautions in case of weld end valves.</li> <li>3. Misalignment of pipe line mating flanges.</li> </ol>	<p>Ensure proper tightening of Body bolting.</p> <p>Suggest following right steps as per our IOM manual.</p> <p>Ensure correct alignment of flanges.</p>
4	High Torque operation	<ol style="list-style-type: none"> <li>1. High temperature of fluid handled.</li> <li>2. Highly viscous fluid handled.</li> <li>3. Insufficient air supply pressure in case of pneumatic operated valves</li> <li>4. Reducing of lever length by user due to less space.</li> <li>5. Pipeline flange pressure in case of single piece valves.</li> </ol>	<p>Check for suitability of material and design.</p> <p>Check for suitability of material and design.</p> <p>Ensure sufficient air pressure.</p> <p>Suggest using levers of correct length.</p> <p>Face the seat or seat seal to relieve extra pressure.</p>
5	Jerky operation	<ol style="list-style-type: none"> <li>1. Presence of foreign particles at seat contact area.</li> <li>2. Peeling of plating of Ball in case of metal seated valves.</li> <li>3. Insufficient air supply pressure in case of pneumatic operated valves</li> </ol>	<p>Dismantle, Clean &amp; Reassemble.</p> <p>Check for service condition/replace.</p> <p>Ensure sufficient air pressure.</p>
6	Gear Operator Damage	<ol style="list-style-type: none"> <li>1. Very high torque operation.</li> <li>2. Poor material of construction &amp; design.</li> <li>3. Transit damage</li> </ol>	<p>Check for causes as covered in Sl.No.4</p> <p>Check for suitability.</p> <p>Replace the damaged spares &amp; report accordingly.</p>

Created - Prepared by		Reviewed by - For suitability & adequacy		Approved by - For suitability & adequacy	
Name	Ningappa.Hubballi	Name	Javeed Soudagar	Name	Shrikant Nayak
Position	Design engineer	Position	Asst.Engineering Manager	Position	General Manager (Technical)
Date	08.08.2018	Date	08.08.2018	Date	08.08.2018
Signature		Signature		Signature	

MICROFINISH - ISO - API - IMS REFERENCES			
LEVEL 01 ISO-API-IMS MANUAL	LEVEL 02 ISO-API-IMS PROCEDURES	LEVEL 03 ISO-API-IMS WORK INSTRUCTION	LEVEL 04 ISO-API-IMS FORMS - FORMATS - RECORDS
MF-L01-P02-MR-DI-001-R06-19052017	MF-L02-P05-D&D-DI-007-R04-19052017	MF-L03-P05-D&D-DI-029.A01-R02-02062017	-

MICROFINISH - ISO - API - IMS - STANDARD CLAUSE REFERENCES			
ISO 9001: 2015, 5TH EDITION	API SPEC Q1, 9TH EDITION	API SPEC 6D, 24TH EDITION	CUSTOMER REQUIREMENT
8.3.5	5.4.3	Nil	Nil

AMENDMENT HISTORY			
Rev No.	Date	Description of the Change   Amendment   Revision	Approval Authority
02	02.06.2017	Existing Work instruction revised & updated for system compliance in line with ISO 9001 : 2015, API Spec Q1, 9 <sup>th</sup> Edition, API 6D 24 <sup>th</sup> Edition addendum - 2 , Errata- 9	General Manager (Technical)
03	08.08.2018	Tightening Torques for Fasteners	General Manager (Technical)